

STREETS, SIDEWALKS, PUBLIC PLACES AND SPECIAL EVENTS

Title 12

STREETS, SIDEWALKS, PUBLIC PLACES AND SPECIAL EVENTS

Chapters:

- 12.04 General Provisions
- 12.08 Driveways and/or Parking Areas in Public Parkway
- 12.12 House Numbers
- 12.20 Trees and Shrubs
- 12.30 Street Improvements
- 12.40 City Corridor Improvement Program
- 12.50 Special Events
- 12.60 Streetlight Banners

GENERAL PROVISIONS

Chapter 12.04

GENERAL PROVISIONS¹

Sections:

12.04.005	Definitions.
12.04.010	Supervision and enforcement authority.
12.04.020	Construction permit - Required - Application.
12.04.030	Pavement - Construction specifications generally.
12.04.040	Pavement - Injury prohibited.
12.04.050	Pavement - Repairs.
12.04.070	Obstruction of public ways prohibited.
12.04.071	Snow removal in downtown district.
12.04.080	Excavations - Barricades required.
12.04.090	Excavations - Disturbing barricades prohibited.
12.04.100	Private use of public places restricted.
12.04.102	Outdoor Cafes and Food Carts in Public Places.
12.04.103	Pushcart Vendors.
12.04.104	Sidewalk Signs.
12.04.110	Encroachments prohibited.
12.04.115	Encroachments - Route 38.
12.04.120	Drains - Obstruction prohibited.
12.04.130	Poles and wires - Permission required for erection or maintenance.
12.04.135	Underground Sprinkling Systems.
12.04.140	Gas pumps - Erection or maintenance on street or sidewalk prohibited.
12.04.150	Openings or stairway - Permit required - Cover or railing required.
12.04.160	Electric or barbed wire fences prohibited.
12.04.170	Deposit on streets.
12.04.175	Spills from vehicles.
12.04.180	Deposit on sidewalks.
12.04.185	Snow removal.
12.04.190	Burning leaves and rubbish.
12.04.200	Obstructing view at corners prohibited - Penalty for violation.
12.04.210	Public way designated.
12.04.215	Acts which constitute violations on bridges and on public property north of Main Street bridge.
12.04.217	Parkway maintenance responsibility.
12.04.218	Mailbox installation and placement.
12.04.220	Violation - Penalty.

12.04.005 Definitions.

For the purpose of this chapter, the following words shall have these meanings:

- A. "Curbing." as defined in Chapter 12.30.030.
- B. "Parkway". A portion of the right-of-way (R-O-W) between the edge of the pavement structure or curbing and the lot or parcel adjacent to the R-O-W. The parkway may include sidewalk, driveway, trees, shrubs, seeded and/or sodded lawn areas and utility services.
- C. "Pavement Structure" as defined in Chapter 12.30.030.
- D. "Right-of-Way" as defined in Chapter 12.30.030.
- E. "Sidewalk" as defined in Chapter 12.30.030.

GENERAL PROVISIONS

- F. "Sidewalk, Approach Type". A parkway structure intended for pedestrian use usually extending from the curbing or edge of pavement right-of-way. This approach sidewalk is intended primarily for the private convenience of the adjacent lot or parcel.
- G. "Utility" as defined in Chapter 12.30.030.
(Ord. 1989-M-47 § 1.)

12.04.010 Supervision and enforcement authority.

All public streets, alleys, sidewalks and other public ways shall be under the supervision of the director of public works. He shall have supervision over all work thereon, and the cleaning thereof, and shall be charged with the enforcement of all ordinance provisions relating to such public places, except traffic ordinances, and is authorized to enforce such ordinances. (Prior code § 12.101.)

12.04.020 Construction permit - Required - Application.

It is unlawful to construct or lay any pavement on any public street, sidewalk, alley or other public way, or to repair the same without having first secured a permit therefor. Applications for such permits shall be made at the office of the director of public works, and shall state the location of the intended pavement or repair, the extent thereof, and the person or firm who is to do the actual construction work. (Prior code § 12.102.)

12.04.030 Pavement - Construction specifications generally.

All streets and sidewalks pavement shall be made in conformity with the specifications and standards as set forth in Ordinance 1960-29. (Prior code § 12.103.)

12.04.040 Pavement - Injury prohibited.

It is unlawful to walk upon or drive any vehicle or animal upon, or injure any newly laid street or alley pavement while the same is guarded by a warning sign or barricade; or to knowingly injure any street, sidewalk or alley pavement. (Prior code § 12.104.)

12.04.050 Pavement - Repairs.

Repair of public street, alley and sidewalk pavement, whether done by the city or the abutting owner, shall be completed under the supervision of the director of public works. (Ord. 1992-M-42 § 1.)

12.04.070 Obstruction of public ways prohibited.

- A. It is unlawful for any firm, corporation, or person to cause, create, maintain, or permit the obstruction of any street, alley, sidewalk, or public way in such a manner that it interferes with the free use and access of such public way, except as may be specifically authorized by ordinance or by the director of public works.
- B. Any person or persons who is at any time found standing, walking, or sitting in a public way in such a manner as to prevent the use or access to such public way to other members of the public and who refuses to disburse or clear the public way and leave the area and clear said public way when requested to do so by any member of the police department or by any person annoyed thereby, shall be presumed to be intentionally obstructing said street, alley, sidewalk, or public way.

(Ord. 1970-M-20: prior code § 12.107.)

GENERAL PROVISIONS

12.04.071 Snow removal in downtown district.

- A. Every individual, partnership, association, corporation, or other business entity in charge or control of any building or lot within the downtown district used for office, retail, commercial, or parking purposes fronting or abutting upon a public sidewalk, whether as owner, tenant, occupant, lessee, or otherwise, shall remove and clear away, or cause to be removed and cleared away, all snow and ice along the entire length and width of the sidewalk fronting or abutting upon the office, retail, commercial building or lot. The downtown district henceforth known as “The Downtown Snow and Ice Removal District” as shown on Exhibit A-12.04.071, and as described as follows:

All that part of the City of St. Charles, lying within those portions of Sections 27 and 34, Township 40 North, Range 8 East of the Third Principal Meridian bounded and described as follows: Beginning at the point of intersection of the center line of Cedar Street and the center line of Fourth Street; thence southerly along said center line of said Fourth Street to the Southerly line of Lot 1, extended Westerly, in Block 50 of the Original Town of St. Charles; thence easterly along the southerly line of Lots 1, 2, 3, and 4 extended, in said Block 50, to the center line of Third Street; thence Northerly along the center line of Third Street to the center line of Walnut Street; thence Easterly along the center line of Walnut to a line that is 129 feet east and parallel to the center line of Third Street; thence Southerly along said parallel line to the Northerly line of Lot 6, Block 43, of the Original Town of St. Charles; thence easterly along the Northerly line of Lot 6, 33 feet, to the Northwest corner of Lot 7, in said Block 43; thence southerly along the Westerly line of said Lot 7 extended to the center line of Illinois Street; thence Easterly along the center line of Illinois Street to the center line of Second Street; thence Southerly along the center of Second Street to the center line of Indiana Street; thence Easterly along the center line of Indiana Street to the west bank of the Fox River; thence Northerly along the west bank of the Fox River to the center line of Illinois Street; thence Easterly along the center line of Illinois Street to the intersection of the center line of Illinois Avenue; thence Easterly along the center line of Illinois Avenue to the center line of Second Avenue; thence Northerly along the center line of Second Avenue to the center line of Walnut Avenue; thence Easterly along the center line of Walnut Avenue to the center line of Third Avenue; thence northerly along the center line of Third Avenue to the center of State Avenue; thence Westerly along the center line of State Avenue to the easterly bank of the Fox River; thence Westerly across the Fox River to the intersection of the west bank of the Fox River and the center line of State Street; thence Westerly along the center line of State Street to the Easterly Line of Lot 2 and Lot 6, extended northerly, of Block 47 of the Original Town of St. Charles; thence Southerly along the East Line of said Lot 2 and Lot 6, extended Southerly, to the center line of Cedar Street; thence Westerly along the center line of Cedar Street to the point of beginning, also being the intersection of the center line of Cedar Street and Fourth Street, all in the City of St. Charles, Kane County, Illinois.

Snow and ice shall be removed within 24 hours after the cessation of any fall of snow, sleet, or freezing rains; provided, however, that if snow and ice on a sidewalk has become so hard that it cannot reasonably be removed without damaging the sidewalk, the person or entity charged with its removal under this section shall, within the 24-hour time period, cause a reasonable amount of sand, salt or other abrasive to be placed upon the entire sidewalk in order to make pedestrian travel thereon reasonably safe; and as soon thereafter as weather permits, such person or entity shall effect the removal of snow and ice as provided for in this section.

- B. Any individual, partnership, association, corporation or other business entity violating any provision of this section shall be subject to a fine of \$50.00 for each day upon which a violation exists.

(Ord. 2003-M-25 § 1.)

12.04.080 Excavations - Barricades required.

GENERAL PROVISIONS

- A. Any person, firm or corporation laying or repairing any pavement on a street, sidewalk or other public place or making an excavation in the same shall maintain suitable barricades to prevent injury of any person or vehicle by reason of the work; such barricades shall be protected by suitable lights at nighttime.
- B. Any defect in any such pavement shall be barricaded to prevent injury; and any person, firm or corporation properly maintaining any opening or excavation in any such place shall guard such opening or excavation while the same remains open, by proper barricades and lights.

(Prior code § 12.108.)

12.04.090 Excavation - Disturbing barricades prohibited.

It is unlawful to disturb or interfere with any barricades or lights lawfully placed to protect or mark any new pavement or excavation or opening in any public street, alley or sidewalk. (Prior code § 12.109.)

12.04.100 Private use of public places restricted.

It is unlawful for any person, firm or corporation to use any street, sidewalk, walkway, plaza or other public place within the public right of way or within property owned or controlled by the City, as space for the display of goods or merchandise for sale, lease, trade or for free or to write or mark any signs or advertisement on any such place, except as provided in Sections 12.04.101, "Sidewalk Sales," Section 12.04.102, "Outdoor Cafes and Food Carts in Public Places," and 12.04.104, "Sidewalk Signs." (Ord. 2007-M-45 § 1; Ord. 2004-M-8 § 1; Ord. 1999-M-48 § 1; Ord. 1996-M-57 § 1.)

12.04.101 Sidewalk Sales.

The city council may designate one or more days a year at its sole discretion when merchandise may be displayed and sold on the sidewalks of the city. However, display of merchandise for sale, lease, trade or for free, shall be confined to the sidewalks and city parking areas adjacent to business zoned property; and, provided further, that the city may require a liability insurance policy naming the city as an additional insured and an indemnity agreement covering all such businesses displaying and selling merchandise. Such liability policy or policies shall be in an amount and issued by such company or companies as are acceptable to the city council. The provision of this section providing for the display and sale of merchandise on sidewalks and city parking areas shall not be construed as a lease, and any/all sales of merchandise pursuant to the provisions of this section shall be in compliance with all ordinances of the city. (Ord. 1996-M-57 § 2; Ord. 1983-M-46 § 1; Ord. 1980-M-34 § 1; prior code § 12.110.)

12.04.102 Outdoor Cafes and Food Carts in Public Places.

- A. The City Administrator is authorized to issue Sidewalk Café Permits for the use of public places located in the CBD-1 zoning district (except for public places located in the First Street TIF District, as hereinafter described), for the purpose of serving food and beverages to the public (including, without limitation, the placement of restaurant tables, chairs, food carts, and similar or related equipment), subject to the following conditions:
 - 1. Permits issued hereunder shall be valid from January 1 or the date of permit issuance, whichever is later, through December 31 of the same year. The permit fee for a Sidewalk Café Permit shall be fifty dollars (\$50.00) for each year the permit is obtained.
 - 2. A Sidewalk Café Permit shall be required prior to placing tables, chairs, umbrellas, enclosure fencing, food carts, or any other equipment on any public sidewalk, or walkway or plaza.
 - 3. Sidewalk Café Permits may be issued only where the equipment is incidental to the operation of a restaurant on private property contiguous to the sidewalk, walkway or plaza.
 - 4. The proposed use shall not unreasonably interfere with pedestrian or vehicular traffic or with access to parked vehicles, and in no event shall the uses permitted by a Sidewalk Café Permit reduce the open portion of any sidewalk or walkway to less than five feet (5') in width. All equipment placed in the public area shall conform with Section 12.04.200 of this Chapter as to corner visibility.
 - 5. Prior to issuance of a permit, the applicant shall furnish a dimensioned plan showing the sidewalk or other public space and all existing public improvements and encroachments such as light posts, benches, planters, trash receptacles, fences, trees and tree grates in the area, bicycle racks and newspaper boxes. The diagram shall also include the location of the curb relative to the building

GENERAL PROVISIONS

- and the proposed location of all café furniture, food carts, and other equipment to be placed on the sidewalk.
6. The consumption and possession of alcoholic beverages in the area for which a Sidewalk Café Permit has been issued shall be prohibited, except as allowed pursuant to Title 5, "Business Licenses and Regulations," Chapter 5.08, "Alcoholic Beverages," Section 5.08.300, "Consumption and Possession of Alcoholic Liquor on Public Property."
 7. All applicable County Health Department sanitation requirements shall be followed for outdoor food handling. The permittee shall be responsible for posting the outdoor seating area as to any special Health Department requirements.
 8. All public areas encompassed by the Sidewalk Café Permit shall be maintained in a sanitary manner at all times. Food scraps and containers shall be disposed of in appropriate refuse containers on a regular basis during the day by the permittee. Sweeping of refuse or food scraps into tree grates is not permitted.
 9. Permittees are responsible for emptying the public trash containers placed by the City if they should become full prior to the next regular pickup time.
 10. Permittees shall see that the public areas encompassed by their Sidewalk Café Permit are clean at the end of each business day, so as not to have any food or drink leftovers remaining which would pose an attraction to animals or insects. Each permit holder shall wash, as needed, the public area to remove any food or drink residue that may attract animals and/or create a pedestrian slip hazard.
 11. Design and placement of tables and chairs, as well as other equipment, shall comply with applicable requirements of the Americans with Disabilities Act and the Illinois Accessibility Act.
 12. No tables, umbrellas, enclosure fencing, or other equipment shall be attached or affixed to the sidewalk, parkway, poles or any other public facilities.
 13. The applicant for a Sidewalk Café Permit shall provide at its sole cost and expense and shall maintain in effect during the entire period of the permit, insurance in the following manner:
 1. Worker's Compensation Insurance in at least the required statutory limits;
 2. Comprehensive General Liability Insurance, including owner's protective liability insurance and contractual liability insurance covering claims for personal injury and property damage with limits of at least two million (\$2,000,000.00) dollars per occurrence, and two million (\$2,000,000.00) dollars for any single injury; and
 3. Prior to issuance of a Sidewalk Café permit, the permittee shall provide the City with copies of the certificates of insurance for the required policies for each type of insurance naming the City as an additional insured party.
 4. The required insurance policies shall each provide that they shall not be changed or cancelled during the life of the Sidewalk Café Permit until 30 days after written notice of such change has been delivered to the City.
 14. The permittee shall indemnify, defend, protect, and hold harmless the City, its corporate authorities, officers, employees, agents and volunteers from and against any and all claims, demands, losses, damages, liabilities, fines, charges, penalties, administrative and judicial proceedings and orders, judgments, remedial actions of any kind, all costs and cleanup actions of any kind, and all costs and expenses incurred in a connection therewith, including but not limited to a reasonable attorney's fees, expert witness fees and costs of defense (collectively, the "Losses") directly or proximately resulting from permittee's acts or omissions, except to the extent that the city is the sole legal cause of said losses. The foregoing notwithstanding, under no circumstances shall the issuance of any permit provided for under the St. Charles Municipal Code, including but not limited to a Sidewalk Café Permit, to the permittee or any other person or entity constitute an act of negligence or willful misconduct. Nothing set forth in the said permit shall be deemed a waiver by the city of any defenses or immunities relating to the permittee or its property, or to any person or entity or their property, that are or would be otherwise available to the city or its corporate authorities, officers, employees, agents and volunteers under the common law of the State of Illinois or the United States of America. The provisions of this section shall survive the expiration or earlier termination of each Sidewalk Café permit, or the renewal thereof.
 15. The City may suspend or revoke the Sidewalk Café Permit for any reason including, but not limited to violations of any provision of the St. Charles Municipal Code after providing at least three (3) days written notice, except in an emergency, to a permittee.

GENERAL PROVISIONS

- B. The City Administrator is authorized to issue Sidewalk Café Permits for the use of public places located in the First Street TIF District for the purpose of serving food and beverages to the public (including, without limitation, the placement of restaurant tables, chairs, food carts, and similar or related equipment), subject to the conditions outlined above as 2. through 15., as well as the following additional conditions:
1. No tables, chairs umbrellas, enclosure fencing, food carts, or any other equipment in the outdoor café area shall obstruct any access areas for emergency vehicles.
 2. If the outdoor café area is fenced in, the door that provides access to the outdoor café area shall not be a required exit for the building, tenant space or unit.
 3. Permits issued hereunder shall be valid for a term of one hundred (100) days or less and shall be issued for the period of April 15 (or the date of application, whichever is later) through July 23 and/or the period of July 24 (or the date of application, whichever is later) through October 31. The holder of a permit for April 15 through July 23 shall not have any automatic right to the issuance of a permit for the period of July 24 through October 31, but shall have the right to apply for a second permit. If a second permit is applied for within a calendar year, the permit fee for the second permit shall be twenty five dollars (\$25.00).

The First Street TIF District is described as follows: That part of the Northwest Quarter and the Southwest Quarter of Section 27, Township 40 North, Range 8, East of the Third Principal Meridian in the City of St. Charles, Kane County, Illinois described as follows: Beginning at the northeast corner of Block 44 in Original Town of St. Charles, said point also being the intersection of the south right-of-way line of Main Street (Illinois Route 64) and the westerly right-of-way line of 2nd Street (Illinois Route 31); thence easterly along said southerly right-of-way line to the west bank of the Fox River; thence southerly along said west bank to the southerly right-of-way line of Indiana Street; thence westerly along said southerly right-of-way line to the easterly right-of-way of 1st Street; thence southerly along the easterly right-of-way line of 1st Street to the northerly right-of-way line of Prairie Street; thence easterly along said northerly right-of-way line of Prairie Street to the northerly extension of the west line of Lot 5 in the Piano Factory of St. Charles Subdivision; thence southerly along the west line of said Lot 5 and the northerly extension thereof to the most southerly corner of said Lot 5; thence southwesterly along the extension of the southeasterly line of said Lot 5 to the westerly right-of-way line of 2nd Street (Illinois Route 31); thence northerly along said westerly right-of-way line of 2nd Street to the Point of Beginning.

(Ord. 2010-M-68 § 1; Ord. 2007-M-45 § 2; Ord. 2004-M-8 § 2; Ord. 1999-M-48 § 2; Ord. 1996-M-57 § 1.)

12.04.103 Pushcart Vendors.

A. Operation of Pushcarts Prohibited

It is prohibited and unlawful to operate a Pushcart within the corporate limits of the City of St. Charles without having first obtained a Pushcart Food Vendor License, or in violation of the terms of such License.

B. License - Application - Limits

1. Applications for Pushcart Food Vendor Licenses shall be made to the Building and Code Enforcement Division and shall be required prior to placing the pushcart equipment on any walkway or plaza. Licenses issued hereunder shall be valid from January 1 of any given year or the date of License issuance; whichever is later, through December 31 of the same year.
2. The License fee for a Pushcart Vendor License shall be fifty dollars (\$50.00) for each year the License is obtained.
3. Prior to issuance of a License, the applicant shall furnish a dimensioned plan showing the dimensions of the pushcart. The required diagram is to include the relative proposed location of the pushcart within the Identified Vending Locations, provided for in Section 12.04.103G, and other equipment related to the conduct of the pushcart vendor business.

GENERAL PROVISIONS

4. The applicant must submit an approved Kane County Health Department Certificate, A Certificate of Insurance, and an Indemnification Agreement at the time of application for a Pushcart Vendor License.
5. In no event shall the number of Licenses issued pursuant to this Chapter exceed three (3) licenses at any given time.
6. In no event shall more than one License be issued to a single vendor, business, or entity.

C. Definitions

For the purposes of this Chapter, the following terms and phrases shall have the meanings ascribed herein, unless the context otherwise requires.

“Approved Food and Beverage Items” shall mean those items authorized to be sold or dispensed from a pushcart or similar contrivance under the regulations of the Kane County Health Department relating to pushcart food units.

“Person” shall mean, but not be limited to, any individual, partnership, co-partnership, firm, company, corporation, association, joint stock company, trust estate, employees, agents, and independent contractors of the same.

“Pushcart” shall mean any cart that is limited to precooked hot dogs, un-shucked cooked corn, whole fresh fruit, canned beverages, condiments, and prepackaged non-potentially hazardous food.

“Pushcart Food Vendor” shall mean any Person that offers to sell or otherwise dispense food or beverages from a Pushcart.

“Identified Vending Areas” shall mean the specific geographical area(s) specified in Section 12.04.103.G, herein.

D. Pushcart Specifications

1. All Pushcarts shall be capable of being pushed by one person and may not be towed or in anyway propelled by an engine or motor.
2. All Pushcarts shall have a frame no greater than three (3) feet wide by five (5) feet long by five (5) feet high.
3. All Pushcarts must have a minimum of two (2) functional rubber tired wheels with a braking mechanism.
4. Pushcarts may be equipped with an umbrella, in which case, the umbrella height shall not exceed eight (8) feet above adjacent grade.
5. No Pushcart shall have attached to it any bell, siren, light, balloon or other inflatable device, horn, loudspeaker or any similar device.
6. No Pushcart shall have a permanent potable water, wastewater, electric connection, or otherwise use an electric extension cord or generator.

E. Rules of Operation

In addition to any other condition or regulation contained in the City Code or in the statutes of the state, the following conditions and regulations shall be applicable to and shall govern and control the operation of Pushcarts.

1. Pushcarts shall not be operated outside of Identified Vending Areas; said vending areas shall be indicated on the Pushcart Food Vendor’s License. *The specific location and dimensions of identified vending locations shall be as designated by the City Administrator. No identified vending location shall have dimensions greater than six feet by eight feet.*
2. Pushcart Food Vendors shall operate only between the hours of 6:30 a.m. and 8:00 p.m. The hours of operation shall be extended to 10:00 p.m. during special events and festivals as may be established by the City Code or as determined by the City Administrator.
3. Pushcarts shall not be stored, parked or left overnight on any street or sidewalk or in any parking space or other property owned or controlled by the City or be located so as to be visible to the public.
4. Pushcarts shall be cleaned daily and shall be maintained in a clean and healthful condition.
5. Pushcarts shall not impede, endanger or interfere with pedestrian or vehicular traffic.

GENERAL PROVISIONS

6. At all times, there shall be a minimum clearance of no less than five (5) feet around the pushcart for the passage of pedestrians.
7. The immediate area around the Pushcart shall be maintained clean of garbage, trash, paper, cups, cans or litter associated with the Pushcart operation. The Pushcart Food Vendor shall be responsible for the proper disposal of waste and trash associated with its operation. In no event shall the Pushcart Food Vendor utilize City trash receptacles, or other City waste disposal containers.
8. Placement of containers for the collection of waste and trash is prohibited on streets, sidewalks or public places.
9. No item related to the operation of a Pushcart shall be placed on the street, sidewalk, public place, or anywhere other than in or on the cart other than a chair/stool, provided however, that the Pushcart, chair/stool and the Pushcart Food Vendor shall all be located within the limits of the identified vending location.
10. Pushcarts shall be attended at all times except in case of an emergency.
11. No Pushcart Food Vendor may sell or dispense any food item or service to any motor vehicle or any operator or passenger thereof, nor to any person standing in a street or roadway.
12. No items of any kind, other than Approved Food and Beverage Items shall be sold or displayed from a Pushcart.
13. The operation of a Pushcart shall not deface, discolor, mar, mark, damage or destroy the public right-of-way. All stains from cooking, wheels, spillage or any other cause shall be removed within forty-eight hours.

F. Other Requirements

1. The Pushcart shall at all times when in operation comply with all requirements and standards of the Kane County Health Department, and it shall be the obligation of the Pushcart Vendor to maintain a current and valid Kane County Health Certificate during the term of the license issued by the City.
2. There shall be prominently displayed on the Pushcart at all times when in operation (1) a certificate of insurance coverage meeting the requirements set forth in this Chapter; (2) the Pushcart Food Vendor's License issued by the City; (3) an Illinois Department of Revenue Registration Certificate and (4) the License issued by the Kane County Health Department as required by regulations of the County Health Department.
3. As a condition to the issuance of a License required herein, each Pushcart Food Vendor shall execute an agreement by which indemnifies and holds the City, its agents, officials and employees harmless from and against any and all claims, damages and actions at law or in equity arising out of or resulting from the Licensed activity.
4. Discontinuation of operation or relocation during certain activities. The vending business activities conducted by a holder of a Pushcart Food Vendor License shall be discontinued or relocated during festivals, construction or maintenance necessitating the use of the location occupied by the vendor, the vending business activities shall be relocated to another identified vending location, if another such location is available and if not, then such business activities shall be discontinued for the duration of festival, construction or maintenance.
5. Pushcart Food Vendors shall comply with the Illinois Retailer's Occupation Tax Act and the St. Charles Home Rule Municipal Retailer's Occupation Tax Ordinance, as applicable.
6. Insurance Required; Indemnification. Pushcart Food Vendors shall at all times carry comprehensive general liability and products and completed operations insurance coverage with limits of not less than two million dollars (\$2,000,000.00) per occurrence and in the aggregate. Such insurance shall be issued by a company authorized to do business in Illinois, and shall include endorsements (1) naming the City, its agents, officials and employees as additional insures; and (2) providing that the policy of insurance shall not be cancelled or materially modified unless thirty (30) days' prior written notice is given to the City. Submittal of appropriate evidence of such insurance coverage to the Building & Code Enforcement Division shall be a condition of issuance of a Pushcart Food Vendor's License and such insurance coverage shall remain in effect for the duration of the Pushcart Food Vendor's

GENERAL PROVISIONS

License. The term of such insurance shall coincide with the term of the Pushcart Food Vendor License.

7. Assignment of an identified vending location to a Pushcart Food Vendor shall not confer any rights in or to the real property, which is the site of the vending location.

G. Identified Vending Locations

The identified vending locations shall correspond to the two (2) downtown locations, as more specifically provided herein.

1. Northeast Quadrant – Freedom Trail from Municipal Center up to Pottawatomie Park property
2. Southeast Quadrant – Path along the Fox River south of the Illinois St. Bridge to Langum Park

H. Conflicts

In the event of a conflict between the requirements of this Chapter and the requirements of the regulations of the Kane County Health Department or any other law, rule or regulation applicable hereto, the stricter requirement shall control.

I. Violation; Penalty

Any person violating any provision of this Chapter shall be subject to the penalties set forth in Section 1.08 of the St. Charles Municipal Code.

(Ord. 2009-Z-12 § 1.)

12.04.104 Sidewalk Signs.

The City Administrator is authorized to issue Sidewalk Sign Permits for the use of public places located in the CBD-1 zoning district, for the purpose of erecting signs that advertise businesses located within the CBD-1 zoning district. The City Administrator may issue two types of Sidewalk Sign Permits: 1) Annual Sidewalk Sign Permits; and 2) Construction Sidewalk Sign Permits, subject to the following conditions:

A. Conditions applicable to all Sidewalk Sign Permits:

- 1) A Sidewalk Sign Permit shall be required prior to placing any sign on any public sidewalk, walkway or plaza. The City hereby reserves the right to limit the number of Sidewalk Sign Permits issued to ensure the proper flow of pedestrian and vehicular traffic, and otherwise to protect the public health, safety and welfare. In that event, permit applications shall be processed and accepted on a first come, first served, basis.
- 2) The sign shall not be attached or affixed to the sidewalk, parkway, pole or any other public facility.
- 3) The sign shall not unreasonably interfere with pedestrian or vehicular traffic or with access to parked vehicles, and in no event shall the sidewalk sign reduce the open portion of any sidewalk to less than five feet (5') in width. The location and height of the sign shall conform with section 12.04.200 of this chapter as to corner visibility.
- 4) The applicant for a Sidewalk Sign Permit shall provide, at its sole cost and expense, and shall thereafter maintain in effect during the entire period of the permit, insurance in the following manner:
 - a) Worker's Compensation Insurance in at least the required statutory limits;
 - b) Comprehensive General Liability Insurance, including owner's protective liability insurance and contractual liability insurance covering claims for personal injury and property damage with limits of at least two million (\$2,000,000.00) dollars per occurrence, and two million (\$2,000,000.00) dollars for any single injury, and
 - c) Prior to issuance of a Sidewalk Sign Permit, the applicant shall provide the City with copies of the certificates of insurance for the required policies for each type of insurance naming the City as an additional insured party.
 - d) The required insurance policies shall each provide that they shall not be changed or cancelled during the life of the sidewalk Café Permit until 30 days after written notice of such change has been delivered to the City.
- 5) The permittee shall indemnify, defend, protect, and hold harmless the City, its corporate authorities, officers, employees, agents and volunteers from and against any and all claims, demands, losses, damages, liabilities, fines, charges, penalties, administrative and judicial proceedings and orders, judgments remedial actions of any kind, all costs and cleanup

GENERAL PROVISIONS

actions of any kind, and all costs and expenses incurred in a connection therewith, including but not limited to reasonable attorney's fees, expert witness fees and costs of defense (collectively, the "Losses") directly or proximately resulting from permittee's acts or omissions, except to the extent that the City is the sole legal cause of said losses. The foregoing notwithstanding, under no circumstances shall the issuance of any permit provided for under the St. Charles Municipal Code, including but not limited to a Sidewalk Sign Permit, to the permittee or any other person or entity constitute an act of negligence or willful misconduct. Nothing set forth in the said permit shall be deemed a waiver by the city of any defenses or immunities relating to the permittee or its property, or to any person or entity or their property, that are or would be otherwise available to the City or its corporate authorities, officers, employees, agents, and volunteers under the provisions of the Illinois Local Government and Governmental Employees Tort Immunity Act, or that are otherwise available to local governments and their corporate authorities, officers, employees, agents and volunteers under the common law of the State of Illinois or the United States of America. The provisions of this section shall survive the expiration or earlier termination of each Sidewalk Sign Permit, or the renewal thereof.

- 6) The City may suspend or revoke the Sidewalk Sign Permit for any reason including, but not limited to violations of any provision of the St. Charles Municipal Code after providing at least three (3) days written notice, except in an emergency, to a permittee."

B. Conditions applicable to Annual Sidewalk sign Permits:

- 1) Annual Sidewalk sign Permits issued hereunder shall be valid from January 1 or the date of permit issuance, whichever is later, through December 31 of the same year. The permit fee for an Annual Sidewalk Sign Permit shall be thirty dollars (\$30.00) for each year the permit is obtained.
- 2) Annual Sidewalk Sign Permits may be issued only where the sign is incidental to the operation of a business on private property contiguous to the sidewalk, walkway or plaza. Only one Annual Sidewalk Sign Permit shall be issued for each business establishment, except that public service signs (i.e., signs indicating the curb location of valet parking or Health Department requirements for sidewalk cafes) may be permitted in addition to the one sign per business.

C. Conditions applicable to Construction Sidewalk Sign Permits:

- 1) From time to time the Director of Public Works shall designate certain areas of the CBD-1 Zoning District as "construction zones". Any area so designated shall be adjacent to a business or businesses. Said designation shall automatically expire upon the completion of construction activities. Within a designated construction zone, a Construction Sidewalk Sign Permit may be issued, regardless of whether an Annual Sidewalk Sign Permit has previously been issued. Signs permitted by a Construction Sidewalk Sign Permit may be located anywhere within the CBD-1 Zoning District, subject to the review and approval of the Director of Community Development in accordance with, but not limited to, all of the conditions of Subsections A and C of this Section 12.04.104. No more than one Construction Sidewalk Sign Permit may be issued for each business. Businesses may combine their advertising with up to four (4) businesses listed on each sign, and any one business may be listed on up to four (4) signs, but in no event shall the total number of Construction Sidewalk Sign Permits exceed one for each business.
- 2) Construction Sidewalk Sign Permits issued hereunder shall be valid for the duration of the Construction Zone designation. There shall be no permit fee for Construction Sidewalk Sign Permits.

(Ord. 2007-M-61 § 1; Ord. 2007-M-45 § 3; Ord. 2004-M-8 § 3; Ord. 1999-M-48 § 3.)

12.04.110 Encroachments prohibited.

It is unlawful to erect or maintain any building or structure which encroaches upon any public street or property or to erect, install or maintain any sign in or on any public street or other public way, except as authorized by other ordinances. (Prior code § 12.111.)

12.04.115 Encroachments - Route 38.

A. Definitions

GENERAL PROVISIONS

1. **Roadway Right of Way** - Those areas existing or acquired by dedication or by fee simple for highway purposes; also, the areas acquired by temporary easement during the time the easement is in effect;
 2. **Project Right of Way** - Those areas within the project right of way lines established by the State which will be free of encroachments except as herein defined;
 3. **Encroachment** - Any building, fence, sign, or any other structure or object of any kind with the exception of utilities and public road signs, which is placed, located, or maintained in, on, under, or over any portion of the project right of way of the roadway right of way where no project right of way line has been established;
 4. **Permissible Encroachment** - Any existing awning, marquee, advertising sign, or similar overhanging structure supported from a building immediately adjacent to the limits of the platted street where there is a sidewalk extending to the building line and which does not impair the free and safe flow of traffic on the highway; the permissive retention of overhanging signs is not to be construed as being applicable to those signs supported from poles constructed outside the project right of way line and not confined by adjacent buildings;
 5. **Construction Easement Area** - That area lying between the project right of way limits and the platted street limits which will permit the State to enter to perform all necessary construction operations.
- B. It shall be unlawful for any person, firm, or corporation to erect or cause to be erected, any ENCROACHMENT (hereinabove defined) within the limits of the project right of way or roadway right of way where no project right of way lines have been established.
- C. Project right of way lines have been established along Illinois Route 38 from Easterly corporate limit (generally referred to as 14th Street/Bricher Road) to Randall Road.
- (Ord. 1995-M-20 § 1.)

12.04.120 Drains - Obstruction prohibited.

It is unlawful to obstruct any drain in any public street or alley. (Prior code § 12.112.)

12.04.130 Poles and wires - Permission required for erection or maintenance.

It is unlawful to erect any poles or wires or maintain any poles or wires over any public place, street, alley or other public way without first having secured permission from the city council. (Prior code § 12.113.)

12.04.135 Underground Sprinkling Systems - Permission Required for Installation and Maintenance in Public Right-of-Way

It is unlawful to construct or install an underground sprinkling system or maintain an underground sprinkling system in any public place, street, alley or other public right-of-way without first having secured a permit agreement and building, right-of-way, and plumbing permits from the city. The permit agreement shall be executed by the Building Commissioner on behalf of the city. It is the owner's sole responsibility to maintain and repair the underground sprinkler system. The owner shall indemnify the city from any and all liability for damages or injury arising from the installation, operation, maintenance, or location of the underground sprinkling system. Applications for an underground sprinkling system to be installed in public right-of-way shall have a permit agreement and covenant attached, prepared by the applicant (adjacent property owner) and reviewed and approved by the Building Department, stating that he has read the requirements for an underground sprinkling system located in the right-of-way and that he agrees to comply with them and that he does for himself, his heirs, successors and assigns indemnify and hold harmless the city from any liability asserted by others in connection with the installation, operation, maintenance, or location of the underground sprinkling system and that they permit the removal of any underground sprinkling system by the city if the underground sprinkling system interferes with municipal use, access, or other rights. The covenant may be recorded at the applicant's expense by the city in the County Recorder's Office. In the event city shall determine it necessary to excavate or have access across the area with the underground sprinkling system, the applicant shall remove the underground sprinkler system at city's direction and in the event of the failure thereof, the city may remove the same at owner's expense. The city shall not be required to replace the same pursuant to removal of underground sprinkling system in any event. The form of the permit agreement and covenant shall be approved by the City Council. (Ord. 1997-M-48 § 1.)

GENERAL PROVISIONS

12.04.140 Gas pumps - Erection or maintenance on street or sidewalk prohibited.

It is unlawful to maintain or erect any gasoline pump or tank in any public street, alley or sidewalk. (Prior code § 12.114.)

12.04.150 Openings or stairway - Permit required - Cover or railing required.

- A. It is unlawful to construct or maintain any opening or stairway in any public street or alley or sidewalk or other public place without a permit from the city council.
- B. All such lawfully maintained openings shall be guarded by a suitable strong cover or railing, with the approval of the director or public works.

(Prior code § 12.115.)

12.04.160 Electric or barbed wire fences prohibited.

It is unlawful to maintain or construct any fence composed in whole or part of barbed wire, or with any similar materials, designed to cause injury to person, or any wire charged with electrical current, anywhere within the city except to protect industrial property in which case barbed wire must be at least six feet above the sidewalk and extend inward of the property. (Prior code § 12.116.)

12.04.170 Deposit on streets.

- A. It shall be unlawful to deposit on any street any material which may make said street slippery including but not limited to leaves and grass or which may be harmful to the pavement or storm drain thereof, or any waste material, or any glass, or other articles which may do injury to any person, animal or property.
- B. Where no other place is available, materials may be deposited in the street preparatory to delivery or use, with the permission of the public works services manager, and notice to the city Police Department; provided, that such deposit does not reduce the usable width of the roadway at the point to less than eighteen feet; and provided, that such material, other than material to be used in actual building construction, shall not be permitted to remain on such street for more than three hours. Any such material shall be guarded by such lights and barricades as the public works services manager shall deem necessary.
- C. It shall be unlawful to remove any snow or ice from any private property and deposit the same upon any public street or alley or any part thereof.
- D. It shall be unlawful to operate any vehicle on any street, alley or other improved roadway when condition of said vehicle is such that soil, clay, mud, stone, gravel or other material drops or falls from the tires or any other part of said vehicle.
- E. The city may, at its election, remove any materials deposited or dropped on any street, alley or other improved roadway within the city in violation of this section, and may charge the cost of said removal to the person responsible for said violation. In addition to the operator of the offending vehicle, both the owner of the vehicle and the owner of the property from which the offending vehicle has proceeded shall be considered responsible for said violation. Muddy tire tracks or other deposit trails leading from a parcel of property shall be considered prima facie evidence of violation of this section by the owner of said property. Even if the city removes said material and charges for said removal, the violator shall not be deemed to have avoided the violation of this section and shall remain liable for the fine provided for violation of this section in addition to the removal charge.

(Ord. 1989-M-80 § 1; Prior code § 12.117.)

12.04.175 Spills from vehicles.

- A. No vehicle shall be so loaded that any part of its load spills or drops onto any street, alley or other improved roadway within the city.
- B. No vehicle shall be operated on any street, alley or other improved roadway within the city, when the condition of said vehicle is such that soil, clay, mud, stone, gravel or other material drops or falls from the tires or any other part of said vehicle.
- C. The driver or operator or person in charge or control of any vehicle propelled or moved upon any street, alley or other improved roadway within the city, from any part of which vehicle there has or is being dropped, expelled, ejected or detached upon or to said improved street, alley, or

GENERAL PROVISIONS

roadway, any soil, clay, mud, stone, gravel, concrete, concrete mix, wood, ashes, glass, or any kind of waste or refuse material, shall take or cause to be taken, all steps required to immediately remove such material from said improved street, alley or roadway.

(Ord. 1989-M-80 § 1.)

12.04.180 Deposit on sidewalks.

- A. It is unlawful to deposit on any public sidewalk any material which may be harmful to the pavement thereof, or any waste material, or any glass or other articles which might cause injury to persons, animals or property.
- B. Merchandise or other articles may be deposited on sidewalks preparatory to delivery; provided, that the usable width of the sidewalk is not thereby reduced to less than four feet; and, provided, that no such article shall remain on such walk for more than one-half hour.

(Prior code § 12.118.)

12.04.185 Snow removal.

It shall be unlawful for any person, firm or corporation to shovel, plow or remove snow from any private property or sidewalk and deposit the same on any public sidewalk or street within the City. (Ord. 1988-M-31 § 1.)

12.04.190 Burning leaves and rubbish.

It is unlawful for any person, firm or corporation to burn any leaves, paper, rubbish or other substances upon any of the public streets, sidewalks or alleys in the city. (Prior code § 12.119.)

12.04.200 Obstructing view at corners prohibited - Penalty for violation.

- A. It is unlawful to construct, or maintain or permit to remain any fence or other structure, or any bushes, or other plants, on the corner lot within twenty feet of the corner formed by the intersection of any two street lines, which obstructs the view, at a height of more than thirty inches above the elevation of the center of the street intersection.
- B. Any person, firm or corporation violating any provision of this section shall be fined not less than five dollars nor more than five hundred dollars for each offense, and a separate offence shall be deemed committed on each day during or on which such obstruction to view is permitted to remain after notice from the police department or any official of the city to remove the same.

(Prior code § 12.121.)

12.04.210 Public way designated.

- A. The pedestrian and motor vehicle entrances and exits located at the municipal parking plaza at the southeast corner of Second Street and West Main Street are declared to be public ways, except those portions specifically designated for the parking of motor vehicles.
- B. All vehicles using said municipal parking plaza are subject to the rules for parking and operating a motor vehicle in and out of said lot as set out in the municipal ordinances of the city.

(Ord. 1970-M-19 §§ 1, 2.)

12.04.215 Acts which constitute violations on bridges and on public property north of Main Street bridge.

It is unlawful for any person to do, or engage in or participate in any of the following acts or things from or while upon any part of any public bridge, including the approaches thereto, or any city property adjacent to the Fox River along the easterly bank of the Fox River from Main Street, north to the first railroad trestle, within the city:

- A. Fish or otherwise engage or participate in the act of fishing in any manner whatsoever;
- B. Throw, cast, swing or otherwise propel or suspend therefrom any string, rope, line, pole, rod, stick or other similar object or thing for any purpose whatsoever, except in case of a bona fide emergency for the purpose of saving or preserving life or property, or both.

(Ord. 1981-M-31 § 1.)

12.04.217 Parkway maintenance responsibility.

GENERAL PROVISIONS

- A. It is the responsibility of the owner of the lot or parcel adjacent to the parkway to mow the lawn areas of the parkway. The height of such grass lawn areas shall be governed by Chapter 8.28.020. If the owner does not maintain the grass lawn area to the height requirements, the nuisance will be handled in accordance with Chapter 8.28.
- B. Exceptions to the responsibility defined in 12.04.217A are described in the "Lawn Maintenance Agreement" which is annually executed by the City of St. Charles with the St. Charles Park District.
- C. It is the responsibility of the owner of the lot or parcel privately served by a sidewalk, approach type, to maintain and repair such sidewalk, approach type.
(Ord. 1989-M-47 § 1.)

12.04.218 Mailbox installation and placement.

Mailboxes shall be installed at a minimum height of 42" above grade and a maximum of 48" above grade. The face of the box shall be a minimum of 12" and a maximum of 18" from the back of the curb or edge of the pavement as the case may be. A diagram of the permissible placement is shown in Exhibit A.
(Ord. 1993-M-19 § 1)

12.04.220 Violation - Penalty.

Any person, firm or corporation violating any provision of this chapter, except Section 12.04.210, shall be fined not less than one dollar nor more than five hundred dollars for each offense, and a separate offense shall be deemed committed on each day during or on which a violation occurs or continues. (Prior code § 12.120.)

STD. DRW. NO.
DATE : 12-18-97

MAILBOX ATTACHMENTS

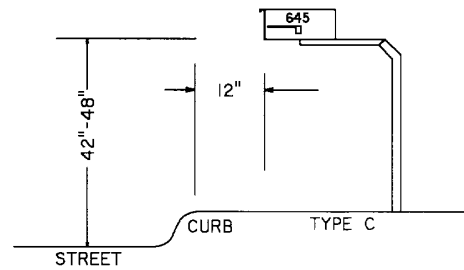
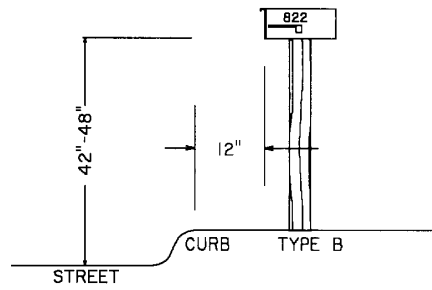
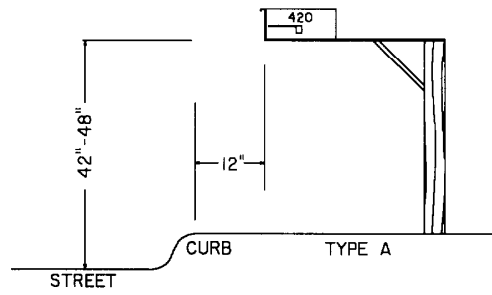

CITY OF ST. CHARLES

GENERAL PROVISIONS

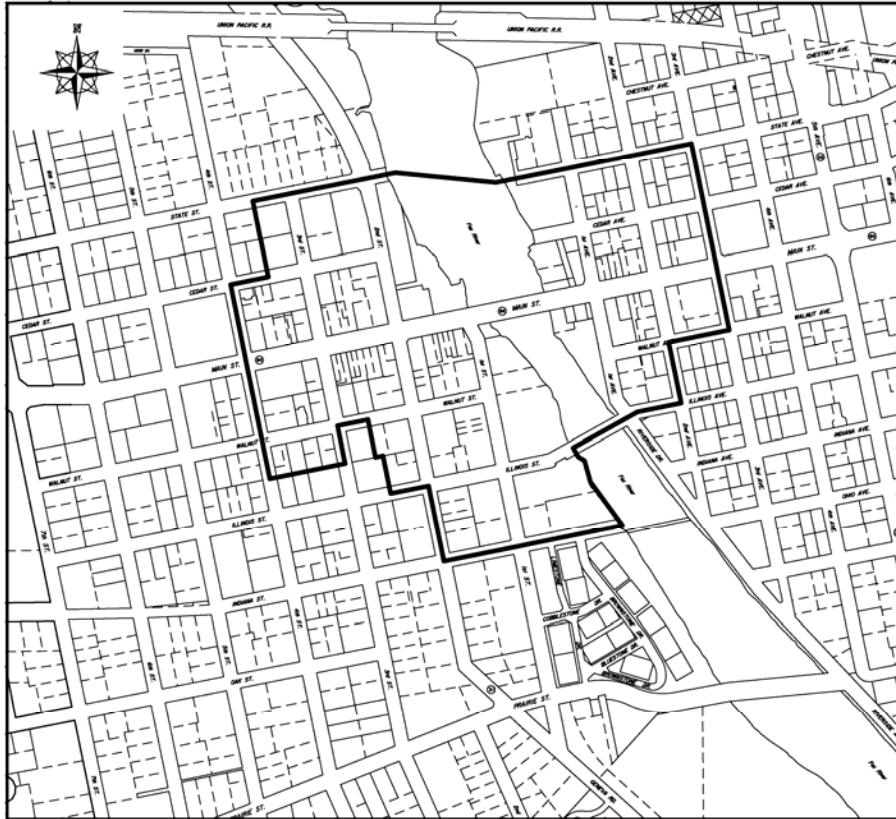

The Downtown Snow & Ice Removal District

———— INTENDED BOUNDARY

EXHIBIT A-12.04.071

CITY OF ST. CHARLES		
ENGINEERING DEPARTMENT		
Downtown Snow & Ice Removal		
DATE:	PHASE:	
DESIGN BY:	CHECK BY:	
DESIGN BY:	APP BY:	
DATE: 1/15/2003	FILE NAME: 1202TALIC.DWG	
REVISION NO.	REVISION DATE	REVISION BY

CITY OF ST. CHARLES
DRAWING NO. 1C of 32

(Ord. 2003-M-25 § 1.)

DRIVEWAYS AND/OR PARKING AREAS IN PUBLIC PARKWAY

Chapter 12.08

DRIVEWAYS AND/OR PARKING AREAS IN PUBLIC PARKWAY²

Sections:

12.08.010	Permit Required.
12.08.020	Bond.
12.08.021	Insurance Requirement.
12.08.030	Fees.
12.08.040	Supervision.
12.08.050	Specifications.
12.08.060	Driveway Grade Surfaces.
12.08.070	Driveway Construction Specifications.
12.08.080	Driveway and/or Parking Area Repair and Maintenance.
12.08.090	Ownership.
12.08.100	Penalty.

12.08.010 Permit required.

No person, firm or corporation shall hereafter construct, build, establish or maintain any driveway and/or parking area over, across or upon any portion of the public sidewalk or public right-of-way without first having obtained a written permit to do so from the Director of Public Works or his designee. Except that when a driveway is included in an application for a permit for a single family dwelling or garage, the application for permit shall be submitted to the Building and Code Enforcement Division Manager per the authorization for the driveway and/or parking area shall be included in the building permit. Authorization shall be obtained from the City prior to construction, establishment or maintenance of a parking area within the public parkway. No permit shall be issued for construction or establishment of any such driveway and/or parking area except in accordance with the provisions herein contained.

Application for permit must be made in writing upon forms furnished by the City. Said application shall contain the name and address of the person, firm, or corporation making the application, the name of the contractor or person who is to construct said driveway and/or parking area and the proposed location and dimensions of such driveway and/or parking area. No parking areas shall be constructed, used or permitted in a public parkway adjacent to a residential use (dwelling; attached/detached single family, multiple-family, two family) in a residentially zoned district. Complete plans and specifications for any driveway and/or parking area, except where included in a building permit application for a single family dwelling or garage, shall be submitted to the Building and Code Enforcement Division Office at least thirty (30) days before permit is desired. The City may refuse to issue a permit for a driveway in instances where it is deemed by the Director of Public Works and the Building and Code Enforcement Division Manager that the proposed driveway will interfere with the operation and/or maintenance of public utilities and/or vehicular traffic. (Ord. 2009-M-35 § 1; Ord. 1995-M-8 § 1.)

12.08.020 Bond.

Before issuance of any such permit the contractor or person proposing to construct such parking area shall file with the City, on a form approved by the City, a permit bond or performance bond in the amount of \$10,000.00 (City of St. Charles listed as beneficiary). This Bond will assure all work, including restoration, is performed in accordance with Chapter 12.30 of the St. Charles Municipal Code. The Permit bond or Performance bond must be an original copy issued by the Bond Insurance carrier, and/or agent; facsimiled copies will not be accepted. The Bond Insurance carrier and/or agent shall save harmless, defend and indemnify the City against or on account of accidents, damages, or claim arising out of or during the construction of any parking area laid by the said contractor. All such bonds shall be valid for a minimum of a one-year term.

(Ord. 2009-M-35 § 1.)

12.08.021 Insurance Requirement.

DRIVEWAYS AND/OR PARKING AREAS IN PUBLIC PARKWAY

Before issuance of any such permit the contractor or person proposing to construct such parking area shall file with the City an original copy of a Certificate of Liability Insurance in accordance with Chapter 13.22.008 of the St. Charles Municipal Code.
(Ord. 2009-M-35 § 1.)

12.08.030 Fees.

The fee for driveway and right-of-way construction permits shall be in accordance with 15.101.150 "Permit and Inspection Fees."
(Ord. 2009-M-35 § 1.)

12.08.040 Supervision.

All such work except driveway constructed in conjunction with single family dwellings and garages shall be done under the jurisdiction of the Director of Public Works and in accordance with the ordinances of the City; and upon completion shall be inspected by such Director or his designee. All driveways constructed in conjunction with single family dwellings and garages shall be done under the jurisdiction for the Building Commissioner and in accordance with the ordinance of the City; and upon completion shall be inspected by such Building Commissioner or his designee.

12.08.050 Specifications.

All plans and specifications must conform to the following minimum requirements before permit for construction or reconstruction shall be permitted.

- A. Construction material is to be concrete or asphalt.
- B. The contractor or other permittee will pay for construction materials, labor and design.
- C. Design and material specifications shall be in accordance with the 'Standard Specifications for Road and Bridge Construction' and supplemental specifications of the current edition by the Illinois Department of Transportation, three copies of which are and have been on file in the City Clerk's Office for at least thirty (30) days prior to the adoption of this Ordinance, which specifications and special provisions are incorporated herein by reference unless otherwise superseded by this title, said specifications and special provisions being sometimes referred to herein as 'Standard Specifications'. (Ord. 2009-M-35 § 1; Ord. 1984-M-71 § 1.)
- D. For parking areas in public parkways the following additional conditions shall apply:
 1. The area must be designed by a professional engineer registered in the State of Illinois.
 2. The professional engineer shall certify that the parking area will not interfere with safe passage of traffic, will not interfere with existing or proposed pedestrian walkways, and will not interfere with the operation, installation or maintenance of utilities, including but not limited to water, sanitary and storm sewer, electric, telephone, gas, cable television and shall comply with Title 18 Storm Water Management Ordinance. (Ord. 2009-M-35 § 1.)
 3. The permittee shall provide a contractor's affidavit and lien waivers in accordance with the Illinois Mechanics Lien Act prior to approval of the parking area by the City. The permittee shall pay for the material and labor costs incurred by the City to restore the parking areas as a result of the installation, operation and/or maintenance of any public utility within the parking area. (Ord. 2009-M-35 § 1.)
 4. All parking areas shall be in accordance with Chapter 17.24 Off Street Parking, Loading, and Access in the St. Charles Municipal Code. (Ord. 2009-M-35 § 1.)
 5. Minimum setback from corners and driveways.
 - (a) Parallel - 20 feet
 - (b) Straight - 20 feet
 - (c) Diagonal - 20 feet
 6. Where practical and reasonable and at the discretion of the City Council, landscape areas may be required to compensate for all or a portion of the lost public parkway vegetative area.

12.08.060 Driveway grade surfaces.

DRIVEWAYS AND/OR PARKING AREAS IN PUBLIC PARKWAY

No driveway shall be so constructed or graded as to leave a step, a sharp depression or other obstruction on the sidewalk. The grade shall be as nearly as possible the same as that of the adjoining sidewalk. It is unlawful to have the surface finish of any driveway, where the same crosses the sidewalk constructed of such materials as to render it slippery or otherwise hazardous to pedestrians, to have the grade of such portion vary from the grade of the sidewalk, or be other than level, or to obstruct the surface drainage.

12.08.070 Driveway construction specifications.

Driveways across sidewalks shall be constructed in compliance with Chapter 12.30 Street Improvements. Where concrete curb and gutter and concrete sidewalk exists, or where installation is imminent, such as would be the case in a new subdivision, then the driveway approach shall be constructed of asphalt or concrete.

12.08.080 Driveway and/or parking area repair and maintenance.

It shall be the duty of the person benefiting from the driveway to keep the driveway and driveway approach on public right-of-way in good repair and free from obstruction and openings. Snow removal from parking areas, driveway and driveway approaches is the responsibility of the owner of the property adjacent the parkway where the parking area, driveway or driveway approach is located.

Restoration obligations. In the event it becomes necessary for the City or its contractors to perform any maintenance or repairs within the City right of way (R.O.W.), the owner agrees that by taking out a permit, the city or its contractors may remove or dig up the 'nonstandard pavement' defined as brick pavers or stamped concrete/bituminous asphalt without notice to the owner. In this event, neither the City or its contractors have any obligation to replace, repair or otherwise reconstruct the "nonstandard pavement"; the responsibility and the cost thereof shall be the obligation of the owner. The Director of Public Works or his designee may, however, authorize a partial cost reimbursement which would reflect the City's cost to repair only the disturbed portion of the "nonstandard pavement." Said reimbursement will be based on the current city secured unit cost for asphalt or concrete based on existing conditions. The owner understands, acknowledges and accepts any and all responsibility for repair, restoration and any and all other work necessary to restore Non-Standard Pavement as a result of City damage during use or access of public R.O.W. shall be owner's responsibility. The City shall have no responsibility under any condition for repair or restoration of Non-Standard Pavement. (Ord. 2007-M-55 § 1; Ord. 2007-M-5 § 1.)

12.08.090 Ownership.

All driveways and parking areas within the public parkway are and shall remain public property irrespective of how and when installed. Parking areas within the parkway may be altered or removed at any time at the sole discretion and direction of the City Council.

12.08.100 Penalty.

Any person, firm or corporation violating any provision of this Chapter shall be fined not less than Five Dollars (\$5.00) nor more than Five Hundred Dollars (\$500.00) for each offense shall be deemed committed on each day during or on which a violation occurs or continues. (Ord. 1984-M-50 § 1.)

Chapter 12.12

HOUSE NUMBERS³

Sections:

- 12.12.010 Numbering plan established.
- 12.12.020 Chart showing street numbers to be kept by city clerk.
- 12.12.030 Owner's responsibility to place number on structure - Penalty for violation.

12.12.010 Numbering plan established.

All lots, buildings and structures in the city shall be numbered in accordance with the following plan: Numbers, as hereinafter designated, are allotted all streets in the city and the basis for such allotment shall be one hundred numbers to each city block, even numbers on the northerly side of all streets running in a northerly and southerly direction; and odd numbers on the southerly side of all streets running in an easterly and westerly direction, and on the westerly side of all streets running in a northerly and southerly direction, and that base street for allotting and designating all numbers shall be as follows:

- A. East Main Street shall be the base for all east numbers on the east side of the Fox River.
- B. Fifth Avenue shall be the base for all north numbers north of East Main Street on the east side of the Fox River.
- C. Seventh Avenue to the intersection with Jefferson Avenue, and the "Moore Road" from said intersection to the southerly city limits, shall be the base for all south numbers south of East Main Street on the east side of the Fox River.
- D. West Main Street shall be the base for all west numbers on the west side of the Fox River.
- E. Fifth Street shall be the base for all north numbers north of West Main Street on the west side of the Fox River.
- F. Third Street and Anderson Boulevard shall be the base for all south numbers south of West Main Street on the west side of the Fox River.

(Prior code § 10.501.)

12.12.020 Chart showing street numbers to be kept by the city clerk.

The city clerk shall keep a chart showing the proper street number of every lot in the city which chart shall be open for inspection by anyone interested therein. (Prior code § 10.502.)

12.12.030 Owner's responsibility to place number on structure - Penalty for violation.

It shall be the duty of the owner and occupant of every single-family and multiple-family dwelling structure in the city to cause every principal building or structure to have posted thereon figures showing the number of that building or structure. It shall further be the duty of the owner and respective occupants of all structures or portions thereof for which an address has been assigned, other than one-family and two-family dwelling structures, in the city to have posted thereon within ten feet of all exterior doors figures showing the number assigned to that structure or portion thereof. Said figures shall be in Arabic numbers which shall be a minimum of three inches in height and of proportionate width, of contrasting color to the mounting surface, and be affixed in such a place to be easily and distinctly read and in plain view from the street. All such numbers shall be placed within ten feet of the front door and shall be visible from the street abutting the front yard. In the event the front door is not on the side of the building or structure facing the street, the requirement of being within ten feet of the front door shall not apply. In an area where the numbers are on a curbside mail box, such numbers shall be on the side of approaching traffic. During construction, buildings shall have temporary numbers affixed to or painted on the structure. This section shall not apply to existing buildings and structures already numbered in a place visible from the street, but shall apply if such numbers are replaced. Any person, firm or corporation failing to so number any principal building or structure owned or occupied by him or it, after receiving notice to do so from the city clerk, shall be fined one dollar for each day on which the failure to so number continues, and each day shall be considered a separate violation. (Ord. 1980-M-19 § 1.)

Chapter 12.20

TREES AND SHRUBS⁴

Sections:

12.20.010	Definitions.
12.20.020	Purpose and intent.
12.20.030	Tree planting requirements.
12.20.040	Tree Commission: establishment, composition, appointment of members.
12.20.050	Tree Commission: duties.
12.20.060	Permits.
12.20.070	Public nuisance—trimming or removal required.
12.20.080	Care and maintenance required.
12.20.100	Wires and poles.
12.20.110	Violation—penalty.

12.20.010 Definitions.

As used within this Chapter, the following terms shall have the meanings set forth in this Section:

- A. **“Parkway”** means a strip of land is part of the dedicated street right-of-way extending from the edge of the street pavement or curb line to the right-of-way property line.
- B. **“Arborist”** The City Arborist of St. Charles, Illinois, a position requiring expertise in the field of arboriculture.
- C. **“Shrubbery”** means a group of low, usually several stemmed woody plants.
- D. **“Property Owner”** The record owner or contract purchaser of any parcel of land.
- E. **“Other Plants”** All vegetation, woody or otherwise, except lawn grass and flowers less than 24 inches in height.
- F. **“Tree”** means a woody perennial plant having main stem or trunk exceeding ten feet in height at maturity.
- G. **“Root Flare”** means the exposed roots that flare out from the base of the tree.
- H. **“Volcano Mulching”** means mulch that has been piled up too high around the trunk of the tree similar to a volcano.
- I. **“ISA”** means International Society of Arboriculture.
- J. **“R.O.W.”** means right-of-way.

(Ord. 2007-M-56 § 1; Ord. 1998-M-28 § 1; Prior code § 12.501.)

12.20.020 Purpose and intent.

- A. Purpose – It is the purpose of this Chapter to promote and protect the public health, safety and general welfare by providing for the regulation of the planting, maintenance and removal of trees, shrubs and other plants within the city.
- B. Intent – It is the intent of the City Council of St. Charles that the terms of this Chapter shall be construed so as to promote:
 1. The planting, maintenance, restoration and survival of desirable trees, shrubs and other plants within the city;
 2. The protection of community residents from personal injury and property damage, and the protection of St. Charles from property damage, caused or threatened by the improper planting, maintenance, or removal of trees, shrubs or other plants located within or affecting city owned property or city right-of-way.

(Ord. 1998-M-28 § 1.)

12.20.030 Tree planting requirements.

These requirements shall apply to any planting of trees as a result of subdivision/development or replacement.

TREES AND SHRUBS

- A. **Size of Street Trees** -- Street trees to be planted or replanted shall have a trunk diameter (measured twelve inches above the ground) of not less than two and one-half inches. All new subdivisions shall have all street parkways planted with trees with a trunk diameter (measured twelve inches above the ground) of not less than two and one-half inches.
- B. **Spacing**
1. Types of trees which attain a mature height of over fifty feet shall be planted not more than forty feet apart and not less than twenty feet apart nor within twenty feet of another tree outside the property line or within the parkway.
 2. Types of trees used that have a mature height of less than fifty feet or are of narrow spreading habit shall be planted not more than thirty feet apart and not less than twenty feet apart nor within twenty feet of another tree outside the property line or within the parkway.
 3. Small ornamental types of trees shall be planted not less than fifteen feet apart or within fifteen feet of another tree outside the property line or within the parkway.
- C. **Location**
1. Trees shall be planted at least five – ten feet from all sidewalks, driveways or other paved areas.
 2. Trees shall be centered in the parkway.
 3. If the width of the parkway is less than five feet, only small ornamental type trees shall be planted.
 4. No tree shall be allowed to be planted if parkway is less than three feet.
 5. Trees shall be at least twenty feet from the property corner at all street intersections.
 6. On corner lots, no planting shall be maintained higher than thirty inches above the centerline grade of the lowest intersecting street if located within the triangular portion of a front or side yard situated within twenty feet of a lot corner formed by the intersection of any two street right of way lines.
 7. Only small ornamental type trees shall be planted under all overhead electric power lines. (Ord. 2007-M-56 § 1)
- D. **Tree Species** – Selection of street trees shall give preference to species native to the Northern Illinois region. All trees shall be transplanted from stock grown in Northern Illinois. The following list of trees is restricted from use in any area covered by this ordinance.

Common Name	Scientific Name
Norway Maple Species	Acer Platanoides
Weeping Willow	Salix Niba
Poplars (except Cottonless Cottonwood)	Populus albo and others
Box Elder	Acer negundo
Tree of Heaven	Ailanthus altissima
Chinese Elm	Ulmus siberica
Female Ginkgo	Ginkgo biloba female
Mulberry	Morus alba and others
Black Locust	Robinis pseudoscacis
Sycamore	Platanus occidentalis
Seedline from soft (silver) maple	Acer Saccharinum
All fruit trees	
All Ash trees	
Pine or Spruce trees	
Russian Olive	Elaeagnus angustifolia

(Ord. 2007-M-56 § 1; Ord. 1998-M-28 § 1; Ord. 1992-M-66 § 1; Ord. 1992-M-47 § 1; Ord. 1988-M-98 § 1; Ord. 1986-M-63 § 12.502; Prior code: § 12.503; 12.504; 12.505; 12.507; and 12.508.)

TREES AND SHRUBS

12.20.040 **Tree Commission: establishment, composition, appointment of members.**

- A. **Establishment** – The St. Charles Tree Commission (hereinafter “Tree Commission”) is hereby established. Its functions and duties are limited to those set forth in this chapter.
- B. **Composition** – The St. Charles Tree Commission shall be composed of nine commissioners. All commissioners shall be appointed by the Mayor with the approval of the Council. All commissioners shall serve without pay. Subject to the exceptions in paragraph “c” immediately below, each commissioner shall serve for a term of four years.
- C. **Appointment of Members** – Four of the nine commissioners initially appointed to the Tree Commission shall serve for a term of two years; five of the nine commissioners initially appointed shall serve for a term of four years. Terms shall start on May 1. Determination of the initial term length (two or four year) shall be by lot. The Chairperson of the Tree Commission shall be elected by majority vote of the Tree Commission and shall be subject to re-election annually on May 1.
- D. **Expiration or Vacation of Terms** – Within thirty days following the expiration of the term of any appointed commissioner, a successor shall be appointed by the Mayor with the approval of the Council, and the successor shall serve for a term of four years. Should any commissioner resign or be removed from the Tree Commission, a successor shall be appointed by the Mayor with the approval of the Council and shall serve for the unexpired period of the vacated term. A member of the Tree Commission may be removed by the Mayor with the approval of a majority of Council.

(Ord. 1998-M-32 § 1; Ord. 1998-M-28 § 1.)

12.20.050 **Tree Commission duties.**

- A. **Duties** – The Tree Commission shall perform the following duties:
 - 1. Within a reasonable time after the appointment of the Tree Commission, upon call of the Chairperson of the Tree Commission, the Tree Commission shall meet and adopt rules of procedure for regular and special meetings to fulfill the duties imposed upon it by this Chapter.
 - 2. The Tree Commission shall advise and consult the Government Services Committee on any matter pertaining to the matters covered in this Chapter and its enforcement. The topics under which this advice and consultation may be given may include, but are not limited to, any of the following:
 - a. Amendment to this Chapter and alteration or revisions of the urban Forestry Plan;
 - b. Policy concerning selection, planting, maintenance, and removal of trees, shrubs and other plants within the City;
 - c. Recommend allocation of funds and expenditures of funds by Department of Public Works for planting and maintenance of trees and shrubs on city-owned property or right-of-way.
 - d. Establishment of educational and informational programs including, but not limited to, yearly Arbor Day celebration.
 - 3. The Tree Commission, with the assistance of the Public Works Department and City Arborist, shall develop, and each subsequent year, update the urban Forestry plan. The plan shall outline urban forestry program activities for a minimum of the next five years. This plan shall describe the urban forestry activities to be undertaken by the city, the reasons for those activities, the possible funding source(s), the means of accomplishing the activities, the alternatives available to the city to fund or accomplish the activity, the projected date of completion and the consequences if the activity is not completed. Activities may include, but are not limited to street tree inventory, planting, tree removal, beautification projects and educational projects.
 - 4. The Tree Commission, with the assistance of the Public Works Department and the City Arborist, shall develop and periodically review and revise, as necessary, the Trees and Shrub ordinance. This ordinance shall contain regulations and standards for the planting, maintenance and removal of trees, shrubs and other plants upon city-owned property and right-of-way.

TREES AND SHRUBS

5. The Tree Commission shall cause the Urban Forestry Plan and the Trees and Shrub Ordinance, and all revisions and amendments to it, to be published and promulgated and shall cause copies of the ordinance and all revisions and amendments to it, to be available for public inspection at the office of the City Clerk. The Trees and Shrub Ordinance and any revisions and additions thereto shall become effective upon the effective date of any ordinance approving the ordinance or revision or amendments thereto.
6. The Tree Commission shall inform the public about the activities of the Tree Commission.
7. The City shall issue such permits as are required by this Chapter and shall obtain as a condition precedent to the issuance of such permits the written agreement of each person who applies for such permits that he or she will comply with the requirement of this Chapter, the Urban Forestry Plan and with the regulations and standards of the Tree and Shrub Ordinance. The Public Works Department shall have the right to inspect all work performed pursuant to such permits. If the Public Works Department finds that the work performed is not in compliance with the requirements of this Chapter, the Urban Forestry Plan or with the regulations or standards of the Tree and Shrub Ordinance, the Public Works Department shall provide written notice of his/her finding to the permit applicant. The notice shall contain a copy of Section 12.20 of this Chapter, and the permit shall be nullified and shall be void and the Public Works Department may issue a written order that the permit applicant cease and desist all work for which the permit was required. The permit applicant shall be subject to penalty under the terms of the Ordinance. The Public Works Department may take steps to correct the results of the non-complying work and the reasonable costs of such steps shall be charged to the permit applicant.

- B. **Public Utility Companies** – Nothing in this section shall be construed to exempt public utility companies or their agents from any of the requirements of this Ordinance.

(Ord. 1998-M-28 § 1.)

12.20.060 Permits.

- A. **Scope of Requirements** – No person or contractor may perform any of the following acts without first obtaining from the City, a permit for which no fee shall be charged. Nothing in this section shall be construed to exempt any person from the requirements of obtaining any additional permits as are required by law. Persons obtaining such permits must have a qualified tree expert. No work shall be done without the City's Arborist approval.
1. Plant on city-owned property or right-of-way, remove or otherwise disturb any tree, shrub, stump or other plant located on city-owned property. Except that this provision shall not be construed to prohibit owners of property adjacent to city-owned property from watering, pruning or fertilizing without a permit, any tree, shrub or other plant located on such city-owned property.
 2. Trim, prune or remove any tree or portions thereof if such tree or portions thereof reasonably may be expected to fall on city-owned property and thereby to cause damage to persons or property.
 3. Mulch applied to City R.O.W. trees must meet with ISA standards. Mulch should not be in contact with trees. No volcano mulching. Mulch should be 2"- 4" thick but dished at trunk to keep mulch from contacting trunk.
 4. Planter boxes that are added after a tree has been planted can only be approximately 4"- 6" higher than root flare. Materials added to box cannot cover root flare or come into contact with trunk. No existing planter boxes can be grandfathered in. Any plants or planter boxes damaged in the removal or maintenance of tree is homeowner's responsibility.
 5. No vegetation shall be planted that interferes with the inspection of the root flare or trunk for parkway tree. Any damage or removal to said vegetation shall not be replaced and is not the responsibility of the City of St. Charles.
 6. Place on city-owned property or right-of-way, either above or below ground level, a container for trees, shrubs or other plants.
 7. Damage, cut, tap, carve or transplant any tree, shrub or other plant located on city-owned property or right-of-way.

TREES AND SHRUBS

8. Attach any rope, wire, nail, sign, poster or any other man-made object to any tree, shrub or other plant located on city-owned property.
- B. **Issuance** – Within seven days of receipt of the application, the Public Works Department shall issue a permit to perform within thirty days of the day of issuance any of the acts specified in Parts (A) and (B), immediately above, for which a permit is requested whenever:
1. Such acts would result in the abatement of a public nuisance; or
 2. Such acts are not inconsistent with the development and implementation of the Urban Forestry Plan or with any regulations or standards of the Tree and Shrub Ordinance; and whenever
 3. An application has been signed by the applicant and submitted to the Public Works Department detailing the location, number, size and species of trees, shrubs or other plants that will be affected by such acts, setting forth the purpose of such acts and the methods to be used, and presenting any additional information that the Public Works Department may find reasonably necessary;
 4. The applicant agrees to perform the work for which the permit is sought in accordance with the provisions of this Ordinance, the Urban Forestry Plan.
 5. The applicant certifies that he or she has read and understands those provisions of the Urban Forestry Plan, this Chapter and of the Ordinance which are pertinent to the work for which the permit is sought.
 6. If the work for which a permit is issued entails the felling of any tree or part thereof, located on private property, which, as a result of such felling reasonably may be expected to fall upon city-owned property or right-of-way, and if such felling is done by one other than the owner of the property on which such felling is done, the applicant agrees to indemnify and to hold the city of St. Charles harmless for all damages resulting from work conducted pursuant to the permit and deposits with the City Clerk a Liability Insurance Policy in the amount of \$100,000 per person/\$300,000 per accident for Bodily Injury Liability and \$50,000 aggregate for Property Damage Liability, which policy shall name St. Charles as an additional insured.
- C. **Public Utility Companies** – Nothing in this section shall be construed to exempt public utility companies or their agents from any of the requirements of this Ordinance.
- D. **Exceptions** – The following persons are exempt from permit requirements noted above:
1. The Public Works Department
 2. Persons hired by or agents of the Public Works Department with proof of insurance
 3. Persons performing work within city right of way authorized by an approved subdivision
 4. Building permit or right-of-way permit
 5. Those acts which the Director of Public Works determines are immediately necessary because of public health and safety hazards

(Ord. 2007-M-56 § 1; Ord. 1998-M-28 § 1.)

12.20.070 **Public nuisance – trimming or removal required.**

- A. **Definition** – The following are hereby declared public nuisances under this Chapter:
1. Any dead or dying tree, shrub or other plant, whether located on city-owned property or right-of-way or which affects or may affect city owned property or right-of-way;
 2. Any otherwise healthy tree, shrub or other plant, whether located on city-owned property or right-of-way, which harbors insects or diseases which reasonably may be expected to injure or harm any tree, shrub or other plant;
 3. Any tree, shrub, other plant or portion thereof, whether located on city-owned property or right-of-way, or on private property, which affects or may affect city-owned property or right-of-way, which by reason of location or condition constitutes an imminent danger to the health, safety or welfare of the general public;
 4. Any tree, shrub or other plant or portion thereof whether located on city-owned property, or right-of-way, private property which affects or may affect city-owned property or right-of-way, which obstructs the free passage of pedestrian or vehicular traffic or which obstructs a traffic control device on city property;

TREES AND SHRUBS

- B. **Right to Inspect** – The officers, agents, servants and employees, of the city have the authority to enter onto private property whereon there is located a tree, shrub, plant or plant part which is reasonably suspected to be a public nuisance, but only to the extent necessary to confirm whether a public nuisance exists.
- C. **Abatement** – The following are the prescribed means of abating public nuisances under this chapter;
1. Any public nuisance under this chapter which is located on city-owned property or right-of-way shall be pruned, removed or otherwise treated by the Public Works Department in whatever fashion is required to cause the abatement of the nuisance within a reasonable time after its discovery.
 2. Any public nuisance such as: Dutch elm disease, Emerald ash borer, and Oak wilt but not restricted to only these nuisances under this chapter which is located on privately-owned property shall be pruned, removed, or otherwise treated by the property owner or his/her agent in whatever fashion is required to cause the abatement of the nuisance. No property owner may be found guilty of violating this provision unless and until the following requirements of notice have been satisfied:
 - a. The Public Works Department shall cause a written notice to be personally served or sent by Certified Mail to the person to whom was sent the tax bill for the general taxes for the last preceding year, or an adult resident or operator of the premises;
 - b. Such notice shall describe by legal description or by common description the premises;
 - c. Such notice shall state the actions that the property owner or occupant may undertake to abate the nuisance;
 - d. Such notice shall require the elimination of the nuisance within thirty days of the date of service of the notice, or such shorter period of time as is deemed necessary for public safety and welfare by the Public Works Department.
 - e. In the event that the nuisance is the Emerald Ash Borer (EAB) the resident shall have until the end of the current or next flight season, as the case may be, to remove infested trees. Flight season runs from May 1 through July 31. (Ord. 2008-M-75 § 1.)
 3. The Public Works Department is empowered to cause the immediate abatement of any public nuisance provided that the nuisance is determined by the Public Works Department to be an immediate threat to any person or property.

(Ord. 2007-M-56 § 1; Ord. 1998-M-28 § 1; Prior code § 12.509.)

12.20.080 Care and maintenance required.

Proper maintenance and care shall be given all newly planted trees and shall be replaced by the party responsible for the new tree if not alive one year after date of planting. The party responsible for maintenance of right-of-way parkway should also be responsible for maintenance (water, fertilizer) of trees in the parkway.

(Ord. 1998-M-28 § 1.)

12.20.100 Wires and poles.

It is unlawful to attach any wire or rope to any tree or shrub on any public street, parkway or other public place without the permission of the director of special services. Any person or company which maintains poles and wires in the streets, alleys or other public places, shall in the absence of provision in the franchise covering the subject, keep such wires and poles free from and away from any trees and shrubs in such places as far as possible, and shall keep all such trees and shrubs near such wires and poles properly trimmed, subject to the supervision of the Director of Public Works or his designee, so that no injury shall be done either to the poles or wires or to the shrubs and trees by their contact.

(Ord. 1998-M-28 § 1; Prior code § 12.510.)

12.20.110 Violation and penalty.

Any person who violates any provision of this chapter or who fails to comply with any notice issued pursuant to the provisions of chapter, upon being found guilty of violation, shall be subject to a fine not to exceed

TREES AND SHRUBS

Seven Hundred Fifty (\$750.00) Dollars for each separate offense, and each day during which any violation of the provisions of this chapter shall occur or continue shall be a separate offense. If, as the result of the violations of any provisions of this Ordinance, the injury, mutilation or death of a tree, shrub or other plant located on city-owned property or right-of-way is caused, the cost of repair or replacement of such tree, shrub or other plant shall be borne by the party in violation. The replacement value of trees and shrubs shall be determined in accordance with the latest revision of *A Guide to the Professional Evaluation of Landscape Trees, Specimen Shrubs and Evergreens*, as published by the International Society of Arboriculture. (Ord. 1998-M-28 § 1; Prior code § 12.511)

STREET IMPROVEMENTS

Chapter 12.30

STREET IMPROVEMENTS

Sections:

12.30.010	Purpose.	
12.30.020	Other Permits.	
12.30.030	Definitions.	
12.30.040	Applicability.	
12.30.050	Standards For Street Design.	
12.30.060	Standards For Street Construction.	
12.30.070	Certification of Documents.	
12.30.080	Street Improvement Required Information/Procedure - Preliminary Plans and Engineering Plans.	
12.30.090	Final Plat - Plat of Dedication - Fees -	Collateral.
12.30.100	Variances.	
12.30.110	Responsibility.	
12.30.120	Interpretation.	
12.30.130	Arrogation and Greater Restrictions.	
12.30.140	Disclaimer of Liability.	
12.30.150	Penalty.	
12.30.160	Corrective Actions.	

12.30.010 Purpose.

The purpose of the chapter is to provide standards for designing and constructing street improvements to enhance the safe passage of vehicular and pedestrian traffic; and to regulate, guide and control the development of street designations in such a manner as to manage and control traffic volumes, and the design and construction of street systems.

12.30.020 Other permits.

Before starting any of the work regulated by this chapter, an applicant shall comply with the provisions of this Chapter and all other applicable provisions of the St. Charles Municipal Code relating to the submission and approval of preliminary and final subdivision plats, improvement plans, building and zoning permits, inspections, appeals and similar matters, and such State and Federal Statutes and Regulations as may be applicable.

12.30.030 Definitions.

For the purposes of this chapter the following definitions are adopted:

- A. **Contractor.** The individual, firm, partnership or corporation contracting with the developer for the construction of prescribed work.
- B. **Developer.** The individual, firm, partnership or corporation planning, initiating and/or managing the street improvement which may be the owner of the land on which the improvement is being constructed.
- C. **Curbing.** The portion of the street improvement primarily constructed to direct surface storm water to a collection point.
- D. **Materials.** Any substances specified for use in the construction of the street improvement and its appurtenances.

STREET IMPROVEMENTS

- E. **Median.** The portion of a divided street separating the traveled ways for traffic in opposite directions.
- F. **Pavement Structure.** The combination of base, and surface course materials placed on a subgrade to support the traffic volume and weight for distribution to the roadbed.
- G. **Plans.** The plans view, profiles, cross sections, working drawings and supplemental drawings, or exact reproduction thereof, which show the location, character, dimensions and details of the work to be done.
- H. **Right-of-way.** A strip of land occupied or intended to be occupied by a street, sidewalk and/or railroad, and by electrical transmission lines, oil or gas pipelines, water mains, sanitary or storm sewer mains, trees, and/or for other special uses. The usage of the term "right-of-way" for land-platting purposes shall mean that every right-of-way hereafter established and shown on a final plat is to be separate and distinct from the lots or parcels adjoining such right-of-way and not included within the dimensions or areas of such lots or parcels. Rights-of-way intended for streets, crosswalks, water mains, sanitary sewers, storm drains, trees, or any other use involving maintenance by a public agency shall be dedicated to public use by the make of the plat on which such right-of-way is established.
- I. **Roadbed.** The graded portion of a street within side slopes, prepared as a foundation for the pavement structure and shoulders or curbing.
- J. **Roadway.** The portion of the right-of-way within limits of construction.
- K. **Shoulder.** The portion of the roadway contiguous with the traveled way for accommodation of stopped vehicles, for emergency use, and for lateral support of base and surface courses.
- L. **Sidewalk.** That portion of the right-of-way primarily constructed for the use of pedestrians.
- M. **Storm Drainage System.** Shall include but not be limited to storm sewer piping, catch basins, manholes, inlet grates and related appurtenances capable of collecting and transporting a 10-year storm frequency based on ISWS Bulletin 70 (dated 1989) rainfall intensities without street flooding or damage to property.
- N. **Street.** That portion of the roadway primarily constructed for use of vehicles.
- O. **Street Improvements.** Any work related to maintaining safe pedestrian and vehicular traffic, and enhancement of the right-of-way.
- P. **Subgrade.** The top surface of a roadbed upon which the pavement structure and shoulders are constructed.
- Q. **Utility.** The privately, publicly or cooperatively owned lines, facilities and systems for producing, transmitting or distributing communications, power, electricity, light, heat, gas, oil, crude products, water, steam, waste, storm water not connected with the highway drainage, and other similar commodities, including combined antenna television cables and equipment, and publicly owned fire and police signal systems and street lighting systems, which directly or indirectly serve the public or any part thereof. The term "utility" as the context shall require, shall also mean the utility company, inclusive of any wholly owned or controlled subsidiary.
- R. **Work.** Work shall mean the furnishing of all labor, materials, equipment, and other incidentals necessary or convenient to the successful completion of the project.

(Ord. 1993-M-52 § 1.)

STREET IMPROVEMENTS

12.30.040 Applicability.

This chapter shall apply to all subdivisions, Planned Unit Developments and Plats of Dedication for Streets, where an engineering plan is approved after the effective date of this chapter. This chapter shall also apply to an unsubdivided parcel of land or to a portion or all of subdivided area where street improvements are proposed.

12.30.050 Standards for street design.

- A. Street pavements shall be designed for a minimum 20 year life.
- B. In order to support street designations provided in chapter 16.20.060, Table I, of the St. Charles Municipal Code the Director of Public Works may request a traffic analysis performed by a member of the Institute of Transportation Engineers and approved by him. The cost of the traffic analysis will be borne by the developer.
- C. The street and pavement structure shall be constructed in accordance with the minimum standards as set forth in chapter 16.20.060, Table I, of the St. Charles Municipal Code, and Standard Drawing 1 attached hereto and made a part hereof.
 1. All "MINIMUM STREET WIDTH" dimensions are measured from the back of the curbing, or when curbing is not included in the project, from the edge of the driving surface.
 2. All "MINIMUM TANGENT" dimensions shall apply between reverse horizontal curves as designed in Table I, Chapter 16.20.060 of the St. Charles Municipal Code.
 3. A cul-de-sac street shall not be more than five hundred feet in length measured along its centerline from the street of origin to the end of its right-of-way, unless there are less than sixteen lots abutting the cul-de-sac street. Each cul-de-sac shall have a terminus of nearly circular shape with a minimum street diameter of 90 feet. The minimum right-of-way diameter along a cul-de-sac shall be 120 feet.
 4. Horizontal curves are required in accordance with the "MINIMUM HORIZONTAL CENTERLINE RADIUS" dimension for a deflection in the horizontal centerline at any one point in excess of 10 degrees.
- D. Provisions shall be made for serving lots abutting a residential access street, or backing lots to the residential collector and major street with a screen planting and/or fence contained in a nonaccess reservation along the rear property line.
- E. The intersection of two streets shall form a 90 degree angle where the centerlines cross along tangent sections for each street. Where one of the street alignments is a horizontal curve, the tangent of the second street shall pass through the curve center of the intersecting street. At no time shall two curved streets intersect. The "MINIMUM TANGENT" allowed at an intersection approach shall be in accordance with Chapter 16.20.060, Table I of the St. Charles Municipal Code.

The intersection of more than two streets shall be avoided. Should specific conditions of design indicate that the intersection of more than two streets is necessary, the developer shall obtain approval from the director of public works prior to proceeding with final engineering plans.

- F. Minor streets shall be aligned so that their use by through traffic will be discouraged.
- G. No half width street improvements shall be permitted.
- H. **CURBING** - Combination concrete curb and gutter, type B-6.12, or combination curb and gutter of greater widths shall be designed as part of the pavement for streets, except for streets in areas zoned "Estates." Roadways in areas zoned "Estate" may be constructed without combination curb and gutter, provided the flow velocity of water in the ditches will not exceed four feet per second. (Ord. 1990-M-41 § 1.)
- I. The **minimum curb radius** at the intersection of two minor streets shall be twenty feet; at the intersection of a minor street and a collector street, the minimum curb radius shall be thirty

STREET IMPROVEMENTS

feet and at the intersection of two collector streets, the minimum curb radius shall be forty feet. All street corners along designated truck routes where the intersecting street leads directly to, from or is within property zoned manufacturing purposes, shall have a minimum radius of 45 feet.

- J. **Concrete sidewalks** shall be constructed along both sides of the street and shall be located within the right-of-way one foot from the right-of-way/property lines unless a variance is granted by the city council for a meandering sidewalk. At any time the right-of-way line is not parallel to the curbing, the sidewalk shall parallel the curbing. Their thickness and size shall conform to Chapter 12.30.060, paragraph C of the St. Charles Municipal Code.
- K. **Street signs** will be installed by the city in accordance with standards of the Illinois Department of Transportation and at all intersections. The developer shall pay for the costs, including labor and materials, for these sign installations. Any variation from the city standard signage for designating streets shall meet the approval of the director of public works.
- L. **Street Light Systems**

1. General Requirements:

- a. Street light will be installed by Developers, including conductors, poles and fixtures, at all intersections and cul-de-sacs and at other locations, as necessary, along the city streets, in accordance with Standard Drawing No. 2 or No. 3.
- b. Developers shall be responsible for the design and installation of all street lighting systems within the city in full compliance with all applicable standards for performance necessary to ensure the security and safety of the public.
- c. The city shall have the right to review street lighting system designs submitted by Developers, in advance of such street light system installations, and to make modifications it considers necessary to ensure that the lighting systems are designed in compliance with the city's own requirements and standards of construction.
- d. Developers shall pay for all of the costs of construction, including labor and materials, as necessary for the successful installation of street lighting systems installed under the terms and conditions of this Ordinance.
- e. Variations from the requirements included as part of the Standard Drawings may be granted if in accordance with prudent engineering practices and if approved, in advance and in writing, by the Director of Public Works or his designee, and the City Council.
- f. Developers shall assume complete responsibility for the maintenance of developer-installed street lighting systems for a period of one-year from the date of initial energization.
- g. After developer-installed lighting systems are installed and working for a full year, the City shall perform an end-of-year inspection of such facilities. If the City determines, during the course of the inspection of such facilities, that such systems are fully functional and operational, and in full compliance with the City's standards, the City shall have the right, but not the obligation, to retain ownership of such facilities, including perpetual responsibility for maintenance.

2. Standards of Construction

All new street lighting systems installed within the city shall be designed and installed in accordance with the following general standards.

STREET IMPROVEMENTS

- a. Street lighting systems shall be designed in compliance with all applicable standards for performance necessary to ensure the security and safety of the public.
- b. The conductors for all new street lighting systems shall be installed exclusively underground.
- c. Street lighting system lighting standards shall be installed at or near lot lines or property lines, as the case may be, in an effort to keep the lighting standards as close as is practical to the source of power.
- d. Developer shall make all reasonable efforts, in the design of street lighting systems, to avoid the crossing of streets, sidewalks and driveways with lighting conductors.
- e. The Director of Public Works or his designee shall have the option of selecting Option No. 1 or Option No. 2 for the basic standard and luminaire selection for any new Development in accordance with the standards hereinafter set forth:

3. **Street Light Additions in Existing Overhead Areas**

This provision allows for the addition of street lights in existing overhead areas and may be of either standard street light design (STD. DRW. No. 2 or STD. DRW. No. 3) or may be mast arm mounted on a wood pole as determined by City staff and other facilities in the area. New light must be installed within City rights-of-way, along streets or alleys.

- a. If the new light is requested by a resident, the resident must obtain written approval from all other property owners within 300 feet of the location of the light. The cost of the light will be divided equally between the City and the requesting property owner/owners. The energy and maintenance will be supplied by the City as with other street lights.
- b. If the new light is requested by the City (by the Director of Public Works or designee) for security or other reasons, City staff will determine the appropriate location and type of street light and install at City's expense. Resident approval is not required by City requested lights.

Option No. 1: As detailed in Standard Drawing No. 2. 12.30.050 (L)

Option No. 2: As detailed in Standard Drawing No. 3. 12.30.050 (L)

- M. The city may require the developer to install traffic signals at intersections in accordance with design standards of the Illinois Department of Transportation. Should traffic signals not be warranted immediately, but in the future not to exceed five years after 100% build out of the platted area, or if the intersection is not part of a subdivision plat within five years following the recording of the plat of street dedication, at the election of the city, the city and developer shall enter into a signalization agreement, whereby the developer or a designated special service area would at a future date pay a portion of the cost of traffic signals. The need for traffic signals will be based upon Illinois Department of Transportation warrant standards.
- N. **Storm drainage system** shall be installed including appropriate stormwater retention and detention facilities in accordance with Titles 16 and 18 of the St. Charles Municipal Code. The proposed storm drainage system shall discharge into an existing storm sewer or drainage way such that the existing system has adequate capacity for the additional flow and adequate provisions shall be made for surface overflow when the capacity for the additional flow and adequate provisions shall be made for surface overflow when the capacity of the storm drainage system is exceeded to ensure that buildings are not flooded or threatened by flooding.
- O. **Median and parkway areas** shall provide for drainage to the storm drainage system. Street trees shall be placed along the right-of-way in accordance with Chapter 12.20 of the St. Charles Municipal Code. The parkway shall be top-soiled and seeded, or sodded.

STREET IMPROVEMENTS

- P. **Temporary Turn Around** - For all temporary dead-end streets, a temporary T-shaped or circular turn around is required at the street end. If no curb cuts for driveway access or other access are intended and if in accordance with generally accepted engineering principles no safety or maintenance problems are apparent as determined by the director of public works, the director may waive the turn around requirement. The turn around surface shall be constructed of asphalt or concrete materials.
 - Q. **Land Strips.** The creation of land strips for landscaping or other purposes shall not be permitted adjacent to a proposed street right-of-way in such a manner as to deny access from adjacent property to such street right-of-way.
 - R. All streets shall be properly integrated with the existing and proposed systems of thoroughfares and dedicated right-of-way as established on a city designated official map and/or a city adopted comprehensive plan.
 - S. All streets shall be properly related to special traffic generators such as industries, business districts, schools, churches, and shopping centers; to population densities; and to the pattern of existing and proposed land uses.
 - T. Minor or local streets shall be laid out to conform as much as possible to the topography, to discourage use by through traffic, to permit efficient drainage and utility systems, and to require the minimum number of streets necessary to provide convenient and safe access to property.
- (Ord. 2003-M-98 § 1; Ord. 1998-M-39 § 1; Ord. 1998-M-23 § 1; Ord. 1989-M-55 § 1.)

12.30.060 Standards for street construction.

- A. All technical standards for street improvements shall be in accordance with the "Standard Specifications for Road and Bridge Construction," adopted July 1, 1988 by the Illinois Department of Transportation, three copies of which are and have been on file in the city clerk's office for at least thirty days prior to the adoption of this ordinance, which specifications are incorporated herein by reference unless otherwise superceded by this title and sometimes referred to herein "Standard Specifications." (Ord. 1990-M-41 § 2; Ord. 1984-M-71 § 2.)
- B. Roadbed construction
 - 1. **Right-of-way Grading** - The contractor shall grade the total right-of-way width to final grade.
 - 2. **Subgrade** - Prior to placing any type of base material, the subgrade shall be inspected and approved by the director of public works or his designee. Twenty-four hours advance notice shall be required for such inspections.

The use of a fabric R underliner such as "Typar" or approved equal, or other stabilization measures may be permitted by the director of public works if the subgrade does not have sufficient bearing capacity as measured by the Illinois bearing ratio test. Minimum Illinois bearing ratios are set forth in Section 16.20.060, Table I, of the St. Charles Municipal Code. A fabric shall not be considered an incremental element in design for a pavement's structural number.
 - 3. **Base Course** - Base course materials acceptable to the city include aggregate, bituminous and concrete base courses. The aggregate base course shall be type B with a CA6 gradation. For concrete streets, Section 304 of Standard Specifications shall apply.
 - 4. **Bituminous Concrete Binder and Surface Course** - Bituminous concrete binder and surface course, shall be Class B modified or Class "I" Mixture C or Class B modified for the surface course.
 - 5. **Portland Cement Concrete Pavement** - The concrete mix shall be uniform throughout and shall contain no less than five percent (5%) nor more than seven percent (7%)

STREET IMPROVEMENTS

entrained air by volume. Concrete in place in the form of finished pavement shall have a minimum of six percent (6%) entrained air.

The minimum twenty-eight (28) day compressive strength shall be four thousand pounds per square inch (4,000 psi). Test cylinders shall be taken and the certified compression test reports submitted to the director of public works.

Curing of newly laid pavement shall be type III of Article 625.01 of Standard Specifications or as approved by the director of public works.

6. **Protective Coat** - All Portland cement concrete pavements, curbing, sidewalk and other concrete construction shall receive a protective coat in accordance with the Standard Specifications.
 7. **Curbing** - Concrete gutter and combination concrete curb and gutter shall be constructed in accordance with Standard Drawings 3 or 4 attached hereto and made a part hereof. Construction joints shall be placed at ten (10') foot (min.) on centers and shall be saw cut to a minimum depth of two (2") inches from front to back of gutter and combination curb and gutter. Contraction joints shall be in place within 24 hours of concrete placement. Three quarter (3/4") inch thick premolded joint filler or bituminous premolded joints shall be installed at 50 foot intervals. Combination curb and gutter shall be depressed at sidewalk ramps for the handicapped in accordance with Standard Drawing 12.30.060.06 attached hereto and made a part hereof. Curbing materials shall be in accordance with Paragraph 12.30.060 B.5 of the St. Charles Municipal Code.
 8. **Shoulder** - Shoulder materials acceptable to the city include aggregate and bituminous concrete. Aggregate shall be type B with a CA6 gradation. Bituminous concrete shoulder shall be Class B modified. The bituminous concrete shoulder shall include a base course, in accordance with Paragraph 12.30.060 B.2 of the St. Charles Municipal Code.
- C. **Sidewalk Construction** - Sidewalk shall be Portland cement concrete in accordance with the material called for in paragraph 12.30.060 B.2 of the St. Charles Municipal Code, and in accordance with Standard Drawing 5 attached hereto and made a part hereof. Sidewalk shall be five (5') feet wide minimum along all collector and major streets and four (4') feet wide minimum along all minor streets and a minimum five (5") inches thick, six (6") inches thick where driveways are located if known prior to sidewalk construction. The base course shall be three (3") inches thick of compacted aggregate. Granular base courses shall be CA6 gradation. All sidewalks shall be provided with handicap accessible concrete approach ramps at all intersections, in accordance with Standard Drawing 12.30.060.06 attached hereto and made a part hereof.
- D. **Temporary Turn Around Construction** - Temporary turn around shall be constructed in accordance with Section 12.30.060B of the St. Charles Municipal Code.
- E. **Parkway Construction** - Parkway construction shall be in accordance with Standard Drawing 5 attached hereto and made a part hereof.
1. The parkway between the sidewalk and curb shall provide cross-drainage to the street with a minimum slope 2% (1/4" per 1') based on a combination concrete curb and gutter, and a maximum cross slope of 25% (3" per 1').
 2. The parkway shall be graded, topsoiled with four inches (4") and seeded, Class I, or sodded. When the parkway is constructed at a gradient of ten percent (10%) or greater, then sodding shall be required. Agricultural ground limestone shall not be permitted.
- F. **Drive Approaches**

STREET IMPROVEMENTS

1. All new drive approaches shall be Portland cement concrete or bituminous concrete, Class I or B modified respectively, in accordance with Standard Drawing 7 attached hereto and made a part hereof. Existing bituminous concrete and concrete drive approaches shall be replaced with like materials.
2. Concrete Drive Approaches - shall be six inches (6") Portland cement concrete, non-reinforced with a continuous three quarter inch (3/4") bituminous fiber expansion joint at the sidewalk and at the back of the curb. The surface shall be scored into a five foot (5') grid. This pavement shall be placed on a compacted stone or gravel base to a depth of five inches (5") minimum.
3. Bituminous Drive Approaches - shall include eight inches (8") minimum of compacted crushed gravel (CA-6) base course with two inches (2") minimum bituminous concrete surface course, Class I or Class B modified.

G. Disposal of Excess Material

1. Disposal of excess material, excluding topsoil, shall be the responsibility of the contractor. Regarding excess topsoil, the city may elect to have the contractor, with developer approval, stockpile this material for municipal use at a later date.

(Ord. 1993-M-51 § 1.)

12.30.070 Certification of documents.

All computations, plans and specifications prepared for compliance with this chapter shall be certified by a registered professional engineer, and a copy thereof submitted with the engineering plans for the street improvement.

12.30.080 Street improvement required information/procedure - Preliminary plans and engineering plans.

- A. Preliminary Plan: A preliminary plan shall have a scale no smaller than 1" = 100'. The plan shall show curve data, including the curve radius, and curve length. The alignment shall be stationed from points of termini. The right-of-way, street and sidewalk shall be shown. A typical cross-section to scale, no larger than 1" = 10, shall also be included showing the street improvements. On such a plan, there shall also be shown the following:
 1. The location of streams, and other floodwater runoff channels.
 2. The location, if known, of drains.
 3. Storm sewers, sanitary sewer, water mains and other utilities.
 4. The location of the existing roadway and street improvements which the new street improvement shall be contiguous to or a part of.
 5. The location of any existing features including structures, trees, etc.
- B. Engineering Plan - The engineering plans for a proposed street improvement, shall include the following information and data:
 1. Engineering plans drawn to scale on 24" x 36" format which shall include complete buildable plans for the street improvement, including the storm sewer in accordance with the requirements for engineering plans specified in Title 16 of the St. Charles Municipal Code, prepared, signed and sealed by a registered professional engineer.
 2. Plan showing recommended locations and easements for electric, gas, communications, and telephone facilities and distribution.
 3. Street storm sewers and other storm drains to be built, the basis of their design, all in accordance with Title 16, of the St. Charles Municipal Code.
- C. Procedure: The procedure for filing the preliminary plan and engineering plans for subdivisions and planned unit developments shall be in accordance with Chapter 16.12 of the St. Charles

STREET IMPROVEMENTS

Municipal Code. For all other types of proposed streets filing of the preliminary plan and engineering plans shall be done by submitting three (3) sets of documents to the city engineer's office with the same level of detail required under Chapter 16.12 of the St. Charles Municipal Code. The review process shall be accomplished through the department of public works and presented to the public works committee for recommendation for the city council. The city council shall be the final determining body to accept or reject the proposed street.

12.30.090 Final plat - Plats of dedication - Fees - Collateral.

- A. The developer shall submit to the city a final plat for a street improvement in accordance with the requirements of Title 16 of the St. Charles Municipal Code for all subdivisions and planned unit developments. The developer shall submit to the city engineer's office a plat of dedication for all other types of proposed streets and in accordance with all appropriate Illinois Revised Statutes.
- B. The developer shall pay the city for the expense to the city performed in the review of the street improvement project. The schedule of fees for a street improvement shall include the following:
 - 1. Engineering review of the preliminary and final engineering plans, and construction inspection shall be based on hourly rates established by the director of public works and approved by city council in accordance with Title 16.12.150 of the St. Charles Municipal Code.
 - 2. Court reporter fees.
 - 3. Recording fees.
- C. The developer shall provide the city with collateral for the street improvement in accordance with Paragraphs 16.12.160 through 16.12.180 of the St. Charles Municipal Code.

12.30.100 Variances.

The city council may grant variances from the regulatory standards of this chapter, in lieu of any other variance procedure, in accordance with the following requirements:

- A. Application: An application for a variation may be made by any person, firm or corporation, or by any office, department, board, bureau or commission of the city of St. Charles.

An application for a variance is filed with the director of public works. An application for a variation shall be on a form provided by the director of public works and shall contain all information required on such form including the following:

STREET IMPROVEMENTS

1. Legal description of property for which a variation is requested;
 2. The requested variation identified;
 3. The reasons which applicant relies upon as justifying the requested variation;
 4. An 8-1/2" x 11" sketch of the property showing all lot lines, street improvements, and adjoining streets.
- B. Notice of Hearing: No variation shall be granted by the city council except after a public hearing before the city council, of which there shall be a notice of the time and place of the hearing published at least once, no more than 30 days nor less than 15 days before the hearing, in one or more newspapers published in the city of St. Charles, Illinois.
- C. Hearing: The city council shall hold a public hearing at which evidence in support of the variation may be presented by or on behalf of the applicant and any evidence presented by interested parties may be heard.
- D. No variance shall be granted unless the applicant for the variance can demonstrate that:
1. An exceptional economic hardship would result without the variance;
 2. The relief granted is the minimum necessary;
 3. There will be no threat to public safety or creation of a nuisance;
 4. No additional public expense will result;
 5. The property in question cannot yield a reasonable return if permitted to be used only under the condition allowed by the regulations governing the district in which it is located;
 6. The plight of the owner is due to unique circumstances, or;
 7. The variation, if granted, will not alter the essential character of the locality.

12.30.110 Responsibility.

The administration of this chapter shall be the responsibility of the director of public works.

12.30.120 Interpretation.

In the interpretation and application of this chapter, the provisions expressed herein shall be held to be the minimum requirements and shall be liberally construed in favor of the city of St. Charles and shall not be deemed a limitation or repeal of powers granted by state statutes.

12.30.130 Abrogation and greater restrictions.

It is not intended by this chapter to repeal, abrogate or impair any existing easements, covenants or deed restrictions. However, where this chapter imposes greater restrictions, the provisions of this chapter shall prevail.

12.30.140 Disclaimer of liability.

This chapter shall not create liability on the part of the city of St. Charles or any officer or employee thereof for any damages which may result from reliance on this chapter or on any administrative decision made thereunder.

12.30.150 Penalty.

Any person who violates any provision of this chapter or fails to comply with any of its requirements shall upon conviction thereof be fined not more than \$500 (Five Hundred Dollars). Each day such violation continues shall be considered a separate offense.

STREET IMPROVEMENTS

12.30.160 Corrective actions.

Nothing herein contained shall prevent the city of St. Charles from taking such other action as it deems necessary to prevent or remedy a violation of this chapter. (Ord. 1984-M-49 § 1.)

STD. DRW. NO.
DATE : 12-18-97

PAVEMENT CROSS SECTION
(URBAN)

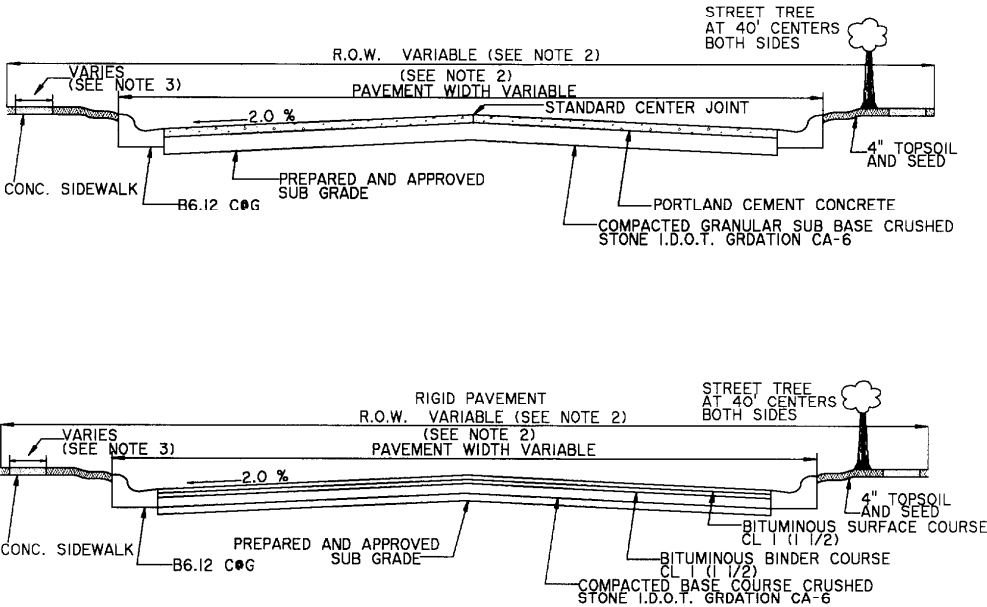

FLEXIBLE PAVEMENT

- NOTES: 1.) REFER TO SECTION 16.20.060 TABLE 1 FOR MINIMUM STRUCTURAL NUMBER REQUIREMENTS.
 NOTES: 2.) REFER TO SECTION 16.20.060 TABLE 1 FOR WIDTH OF R.O.W. AND PAVEMENT.
 NOTES: 3.) SIDEWALKS SHALL BE 5 FEET WIDE ALONG COLLECTOR AND MAJOR STREET AND 4 FEET WIDE ALONG MINOR STREETS.

CITY OF ST. CHARLES

file: 107L\ROADS\XSECTION.DTL

DATE : 10-23-03
 STD. DRW. NO. 2

DECORATIVE STREET LIGHT STANDARD

- KEY:
- (A) CABLE OPENING IN BASE = 2" X 12"
 - (B) HAND HOLE OPENING IN POLE = 3" X 4 1/4" X 7"
 - (C) PHOTO ELECTRIC CELL RECEPTACLE
 - (D) 5/8" X 8' GROUND ROD
 - (E) TWO PIECE FIBERGLASS BASE COVER

RECOMMENDED FIXTURE - ANTIQUE
 #DLT30S/BK-S70/QVIII-TLP
 OR APPROVED EQUIVALENT

WHATELY LAMP POST - MADISON SERIES 305 - DIRECT BURIED POLE WITH 12' MOUNTING HEIGHT OR APPROVED EQUIVALENT

BLACK FINISH

CABLE: 2 CONDUCTOR #10 A.W.G. COPPER UF, 600 VOLTS WITH #10 BARE GROUND TO BE TRENCHED TO THE CLOSEST PEDESTAL OR TRANSFORMER.

VOLTAGE: 120 OR 240V (RESIDENTIAL)
 120, 208, 240, 277V (COMMERCIAL)
 (TO BE DETERMINED BY ENGINEERING)

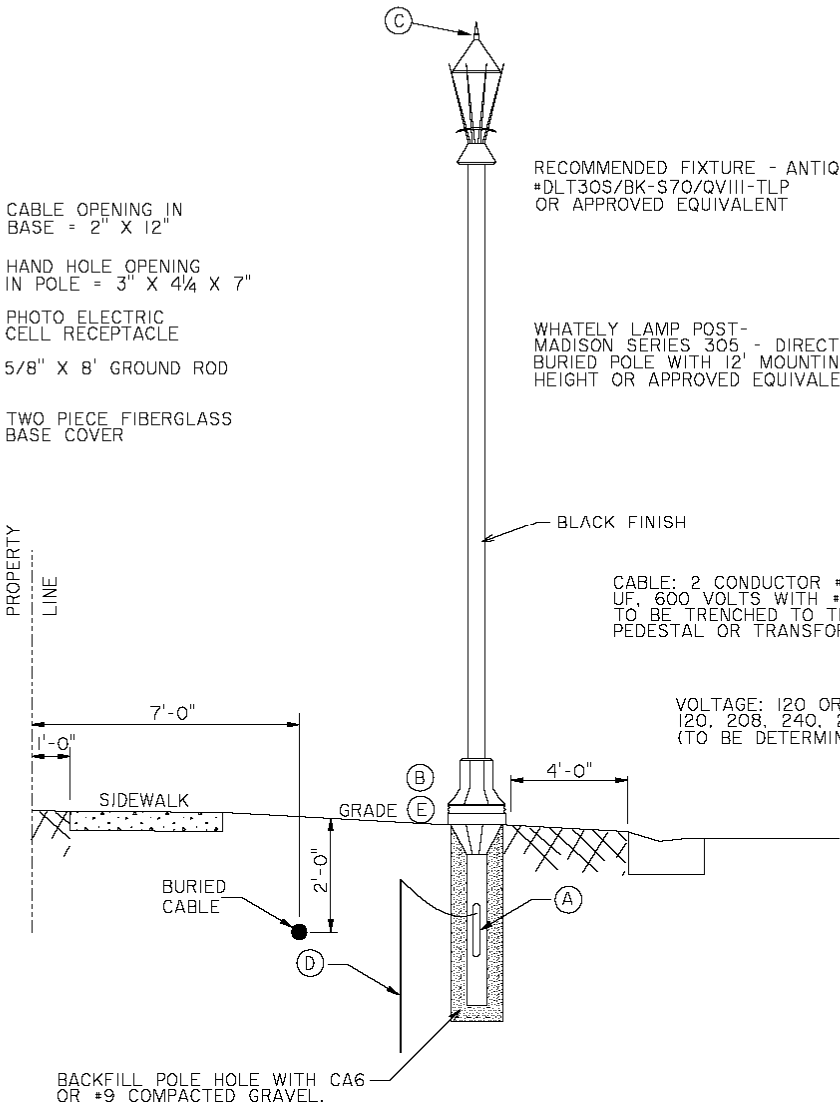

CITY OF ST. CHARLES

FILE: 3ELENDetail.LITEPOLE.DGN

12.30.05(L)

(Ord. 2003-M-98 § 1; Ord. 1998-M-39 § 1; Ord. 1998-M-23 § 1.)

DATE : 10-23-03
STD. DRW. NO. 3

ROADWAY STREET LIGHT INSTALLATION

POLE:
 WHATLEY #DB640253158S
 24" RISE 6' MAST ARM
 TEXTURED GRAY FINISH

CONDUCTOR:
 2 CONDUCTOR #10 A.W.G. COPPER
 TYPE UF, 600 VOLTS WITH BARE GROUND.
 TO BE TRENCHED TO THE CLOSEST
 PEDESTAL OR TRANSFORMER.

VOLTAGE:
 120V OR 240V RESIDENTIAL SUBDIVISIONS
 120V, 208V, 240V, OR 277V (COMMERCIAL)

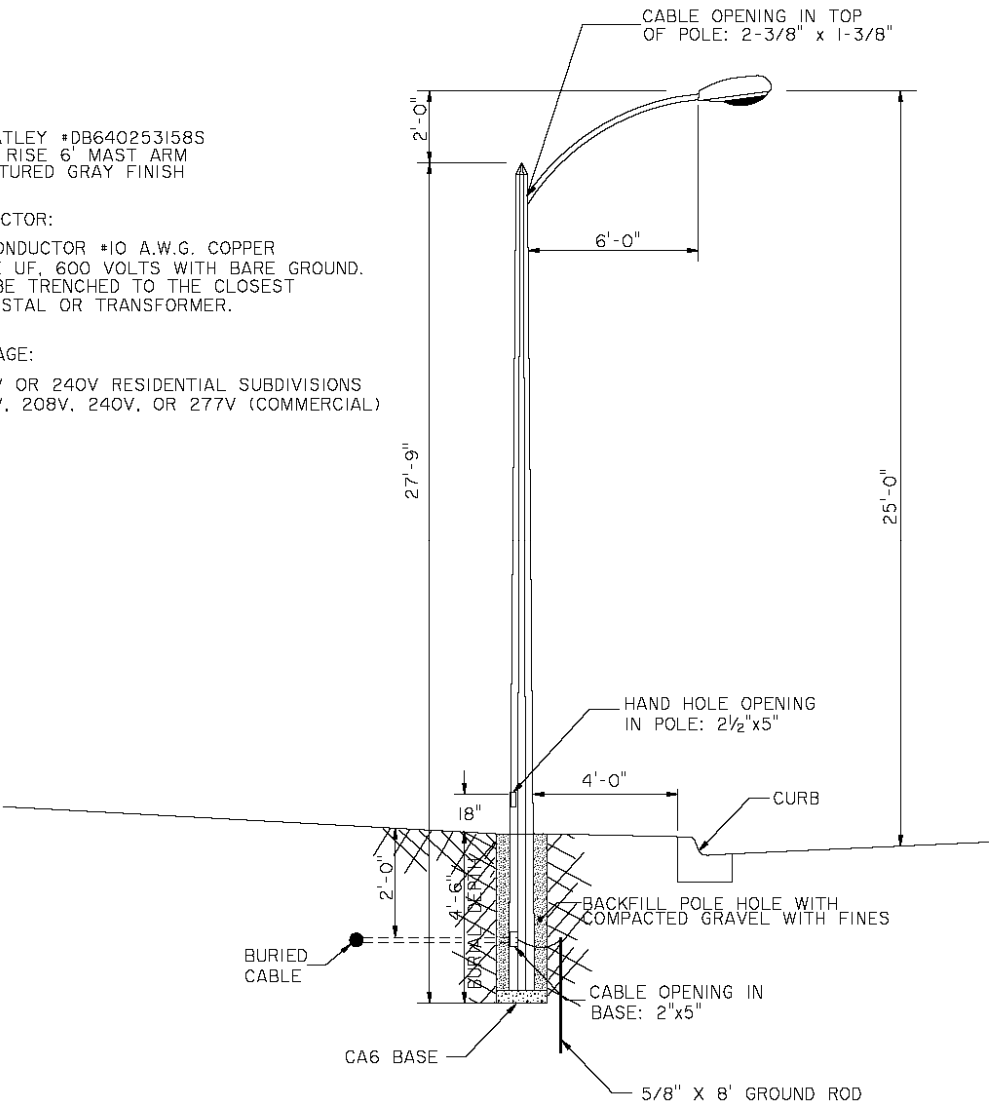

CITY OF ST. CHARLES

FILE: 3ELEDETAIL\LITEPOLE.DGN

12.30.05(L)

(Ord. 2003-M-98 § 1; Ord. 1998-M-39 § 1; Ord. 1998-M-23 § 1.)

STD. DRW. NO.
DATE : 01-05-98

B 6.12 CURB (DEPRESSED)

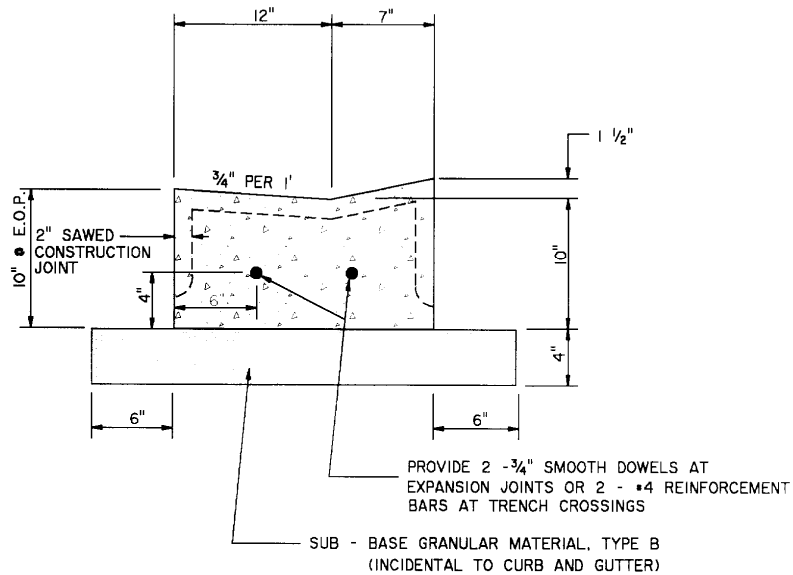

NOTES:

- 1.) 1/2" THICK PREFORMED EXPANSION JOINTS SHALL BE INSTALLED AT 50 FOOT INTERVALS. PROVIDE 2-3/4" STEEL DOWEL BARS AT EXPANSION JOINTS.
- 2.) EXPANSION JOINTS SHALL BE INSTALLED ON EACH SIDE, A DISTANCE OF 2 FEET FROM A STRUCTURE THAT FALLS WITHIN THE CURB AND GUTTER.
- 3.) CONSTRUCTION JOINTS SHALL BE SAWED TO A MINIMUM DEPTH OF 2 INCHES AND PLACED AT 10 FOOT INTERVALS. SAW CUTS SHALL BE SAWED NO SOONER THAN 6 HOURS AND NO LATER THAN 24 HOURS AFTER PLACEMENT OF CONCRETE.
- 4.) CURBS SHALL BE CONSTRUCTED IN ACCORDANCE WITH THE "STANDARD SPECIFICATIONS FOR ROAD AND BRIDGE CONSTRUCTION" (IDOT). MOST RECENT EDITION UNLESS NOTED OR DEPICTED HEREIN.
- 5.) A PROTECTIVE COAT SHALL BE APPLIED IN ACCORDANCE WITH THE STANDARD SPECIFICATIONS.

CITY OF ST. CHARLES

FILE: IDTLVROADVCURBS.DTL

STREET IMPROVEMENTS

STD. DRW. NO.
DATE : 12-17-97

TYPE B6.12 COMBINATION CONCRETE CURB & GUTTER

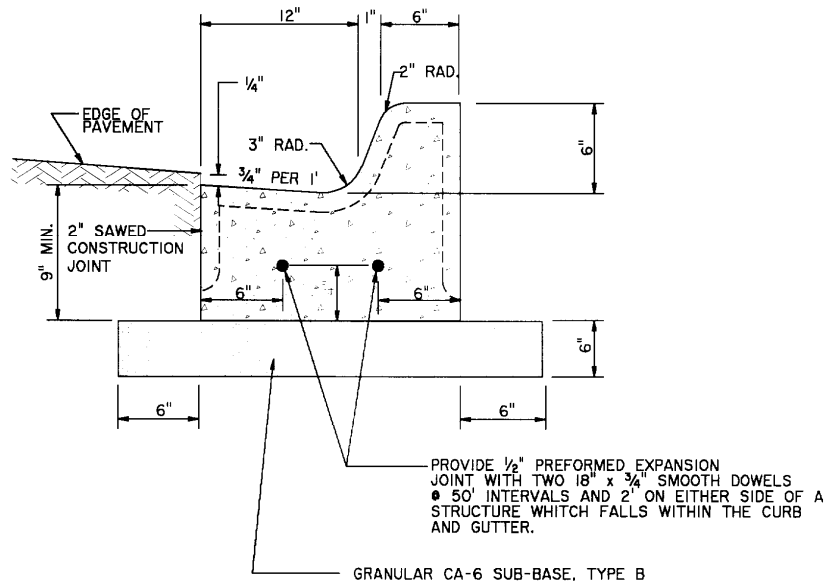

NOTES:

- 1.) 1/2" THICK PREFORMED EXPANSION JOINTS SHALL BE INSTALLED AT 50 FOOT INTERVALS. PROVIDE 2-3/4" STEEL DOWEL BARS AT EXPANSION JOINTS.
- 2.) EXPANSION JOINTS SHALL BE INSTALLED ON EACH SIDE, A DISTANCE OF 2 FEET FROM A STRUCTURE THAT FALLS WITHIN THE CURB AND GUTTER.
- 3.) CONSTRUCTION JOINTS SHALL BE SAWED TO A MINIMUM DEPTH OF 2 INCHES AND PLACED AT 10 FOOT INTERVALS. SAW CUTS SHALL BE SAWED NO SOONER THAN 6 HOURS AND NO LATER THAN 24 HOURS AFTER PLACEMENT OF CONCRETE.
- 4.) CURBS SHALL BE CONSTRUCTED IN ACCORDANCE WITH THE "STANDARD SPECIFICATIONS FOR ROAD AND BRIDGE CONSTRUCTION" (IDOT). MOST RECENT EDITION UNLESS NOTED OR DEPICTED HEREIN.
- 5.) A PROTECTIVE COAT SHALL BE APPLIED IN ACCORDANCE WITH THE STANDARD SPECIFICATIONS.

CITY OF ST. CHARLES

file: IDTL\ROAD\CURB.DTL

STD. DRW. NO.
DATE : 12-18-97

SIDEWALK & PARKWAY RESTORATION

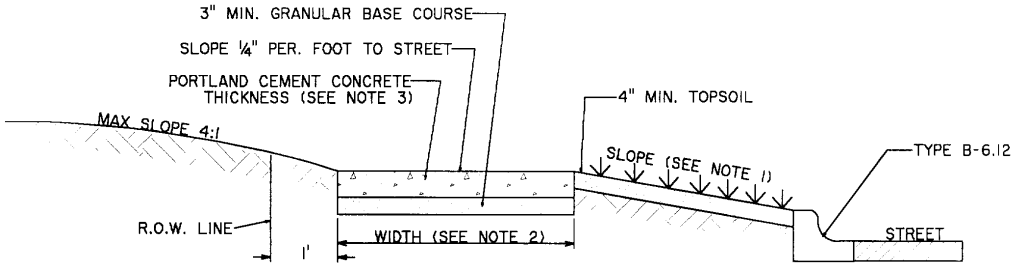

TYPICAL SIDEWALK SECTION IN CUT AREA

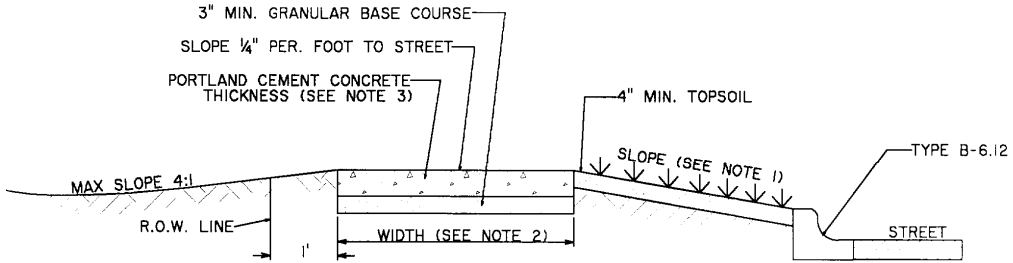

TYPICAL SIDEWALK SECTION IN FILLED AREA

- NOTES:
- 1.) SLOPE SHALL BE AT MINIMUM 1/4" / FT, HOWEVER NOT TO EXCEED 4:1 (HORIZ.: VERTICAL)
 - 2.) SIDEWALK WIDTH ALONG COLLECTOR AND MAJOR STREETS 5 FEET, ALONG MINOR STREETS 4 FEET
 - 3.) SIDEWALK SHALL BE A MINIMUM OF 5" THICK, AND A MINIMUM OF 6" THICK AT DRIVEWAYS

CITY OF ST. CHARLES

file: IOCCOP\PETER\STRIMPR.DGN

STD. DRW. NO. 12.30.060.06
DATE : 10-11-05

SIDEWALK RAMP

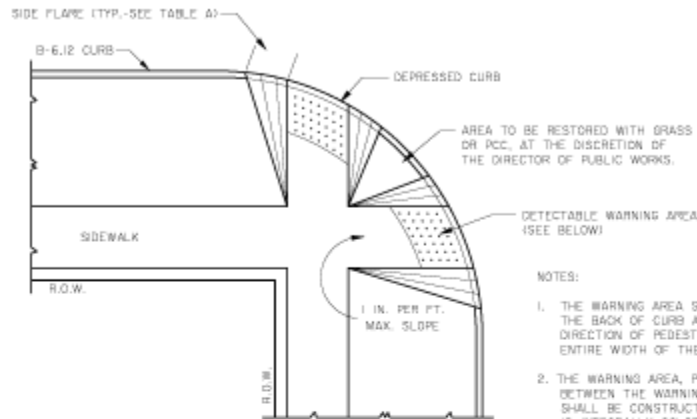
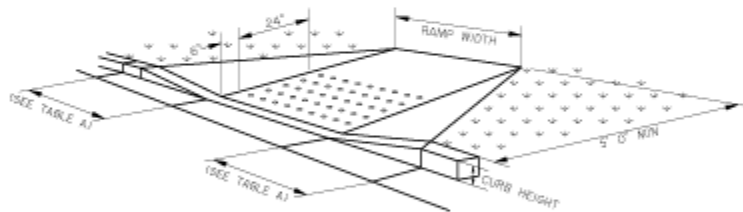

TABLE A
DESIRABLE MINIMUM FLARE WIDTHS FOR VARIOUS CURB HEIGHTS

CURB HEIGHTS (INCHES)	FLARE WIDTH (INCHES)
3	30
4	40
5	50
6	60
7	70
8	80
9	90

- NOTES:
1. THE WARNING AREA SHALL BEGIN 6 INCHES FROM THE BACK OF CURB AND CONTINUE 2 FEET IN THE DIRECTION OF PEDESTRIAN TRAVEL FOR THE ENTIRE WIDTH OF THE WALKING SURFACE.
 2. THE WARNING AREA, PLUS THE 6 INCH AREA BETWEEN THE WARNING AREA AND BACK OF CURB, SHALL BE CONSTRUCTED OUT OF CONCRETE THAT IS INTEGRALLY COLORED RED.
 3. IF THE SIDEWALK IS BRICK OR OF SOME DARK COLOR, THE WARNING AREA SHALL BE A NORMAL (GREY) COLOR OF CLASS 31 CONCRETE TO MEET THE CONTRAST REQUIREMENT.
 4. THE CONCRETE SURFACE SHALL BE FLUSH WITH THE GUTTER FLAG FOR THE ENTIRE RAMP WIDTH AND INCLUDING SIDE FLARES.

SIDEWALK RAMP PLAN



DETECTABLE WARNING DETAIL

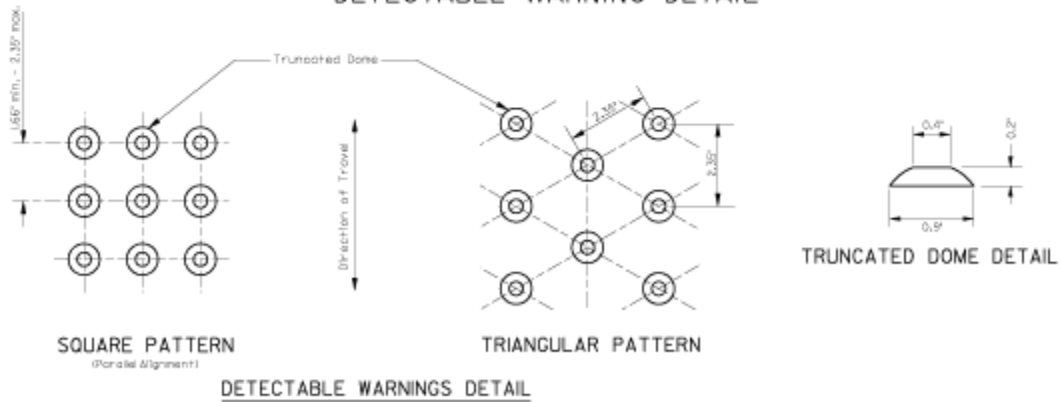

CITY OF ST. CHARLES

FILE: F:\Files\Usindgn\Eng\Greg\Details-4.dgn

(Ord. 2006-M-19 § 1; Ord. 1993-M-51 § 1.)

STD. DRW. NO.
DATE : 12-22-97

DRIVEWAY APPROACHES

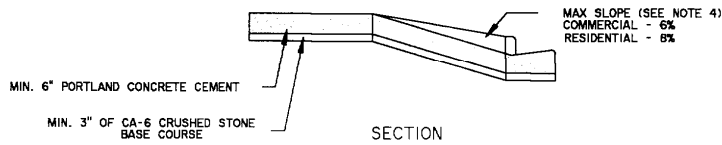
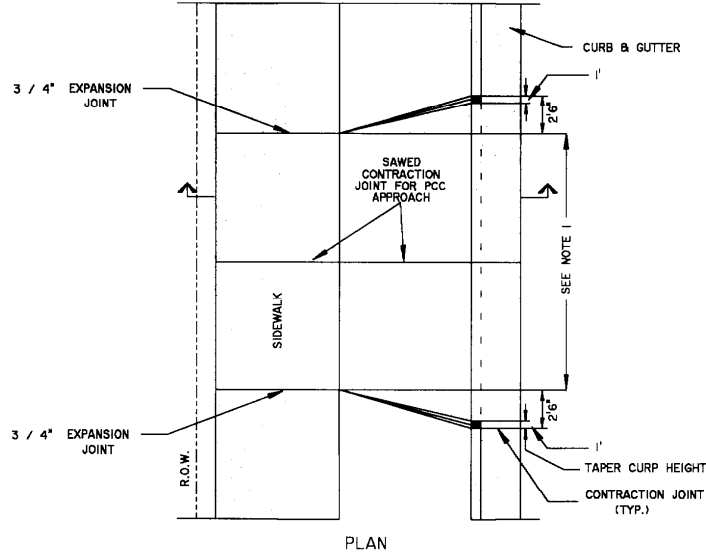

NOTES:

- 1.) RESIDENTIAL DRIVEWAY WIDTH SHALL BE 10 FT. MIN AND 24 FT. MAX.
- 2.) DRIVEWAY SHALL BE AS NEAR 90 DEGREES, AS SITE CONDITIONS PERMIT, BUT NOT LESS THAN 60 DEGREES.
- 3.) THE CONCRETE GUTTER THRU THE DRIVEWAY APPROACH SHALL BE IN ACCORDANCE WITH CITY STANDARD DRAWING NO. 3.
- 4.) MAX SLOPES APPLY TO NEW CONSTRUCTION. WHERE DRIVEWAYS ARE BEING RECONSTRUCTED, THE MAX SLOPE SHALL NOT EXCEED THE PRE-CONSTRUCTION CONDITION.

CITY OF ST. CHARLES

file: IDTL\ROADS\DRIVEWAY.DGN

CITY CORRIDOR IMPROVEMENT PROGRAM

Chapter 12.40

CITY CORRIDOR IMPROVEMENT PROGRAM

Sections:

12.40.010	Purpose.
12.40.020	Definitions.
12.40.030	Corridor Improvement Commission: Membership.
12.40.040	Duties of the Corridor Improvement Commission.
12.40.050	Grant Application Procedure.
12.40.060	Corridor Improvement Agreements.
12.40.070	Funding Source.

12.40.010 Purpose.

The purpose of this Chapter is to promote and protect the public health, safety and welfare by establishing the Corridor Improvement Program and providing for the administration thereof. The Corridor Improvement Program is intended to improve the aesthetics of Eligible Properties by providing financial assistance to property owners or tenants to subsidize the construction of Eligible Improvements. Said improvements shall:

1. Enhance the overall economic vitality and character of the City through improvement of private property; and,
2. Protect the general welfare by aesthetically enhancing Eligible Properties; and,
3. Create and maintain physical improvements that enhance community character by providing unique and familiar visual features.

(Ord. 2009-M-8 § 1; Ord. 2001-M-24 § 1.)

12.40.020 Definitions.

As used in this Chapter, the following terms shall have the meanings set forth herein:

“Corridor Improvement Agreement”: An agreement between a property owner or tenant and the City that provides for the amount of the Corridor Improvement Grant, the improvements to be completed and the responsibilities of the property owner or tenant.

“CIC”: The St. Charles Corridor Improvement Commission.

“Corridor Improvement Grant” or “Grant”: Financial assistance to Grant Recipients to reimburse the cost of Eligible Improvements. Grants may be awarded in the specific forms set forth in the program description attached to this Ordinance as Exhibit “A”, and incorporated herein by this reference.

“Eligible Improvements”: The design, purchase and planting or construction of Landscaping Materials on an Eligible Property.

“Eligible Properties”: Properties located within the corporate limits of the City of St. Charles and: (a) have a frontage on Main Street, Randall Road or Kirk Road; or (b) are located in the Downtown Special Services Area (SSA-1B).

“Grant Recipient”: The owner of record or tenant of an Eligible Property or such other party having a legal interest therein.

“Landscaping Materials”: Plants, trees, shrubs, bulbs, flowers and other similar elements approved by CIC.
(Ord. 2009-M-8 § 1; Ord. 2001-M-24 § 1.)

12.40.030 Corridor Improvement Commission: Membership.

- A. Establishment. The St. Charles Corridor Improvement Commission is hereby established.
- B. Authority. The CIC shall have only those powers and duties provided for in this Chapter 12.40.

CITY CORRIDOR IMPROVEMENT PROGRAM

- C. Membership. There shall be seven (7) members of the CIC, appointed by the Mayor with the advice and consent of the City Council.
- D. Qualifications. CIC members shall be chosen based upon their professional knowledge, commitment to the community and who are:
 - 1. A design professional such as a landscape architect, landscape designer or artist; or
 - 2. A land development professional such as a real estate developer, realtor, construction contractor/planner or civil engineer; or
 - 3. The owner or manager of a business located in the City of St. Charles; or
 - 4. An “at large” member who resides in the City corporate limits, but does not necessarily own a business or work within the City; or
 - 5. Possess other beneficial skills that include, but are not limited to financial/accounting knowledge, interest in the arts (especially a working knowledge of public art) and riverfront issues such as design or ecology.
- E. Terms.
 - 1. Except as provided for herein, members shall be appointed to a term of three (3) years. Of the first five (5) members of the Board, two (2) members shall serve from their dates of appointment through April 30, 2010, and three (3) members shall serve from their dates of appointment through April 30, 2011.
 - 2. All future terms shall expire on April 30 of the last year of their respective terms. Members whose terms have expired shall continue to serve until a successor is appointed, except if a member is removed for cause.
- F. Removal. Members may be removed from the CIC for cause, upon the recommendation of the Mayor or a motion proposed by the City Council, by a two-thirds (2/3) majority vote of the City Council. Any member of the CIC who fails to attend one-third (1/3) or more of the meetings held within any six (6) month period may be so removed.
- G. Compensation. No person shall receive compensation for serving as a member of the CIC.
- H. Officers. The CIC shall elect from its membership a chairperson and a vice-chairperson, and such other officers as it may determine. Officers shall serve for terms of one (1) year, commencing May 1 and ending April 30 of the following year, and shall be eligible for re-election.
- I. Quorum. A quorum shall consist of a majority of the members then sitting on the CIC. Official actions shall be made by a majority of those members present at any meeting where a quorum exists.
- J. Meetings. Meetings shall be held at regularly scheduled times or at the call of the chairperson in accordance with the Illinois Open Meetings Act. Minutes of the proceedings of each meeting shall be made and kept as required by law.
(Ord. 2009-M-8 § 1; Ord. 2001-M-24 § 1.)

12.40.040 Duties of the Corridor Improvement Commission.

- A. Duties. The CIC shall perform the following duties:
 - 1. Adopt rules of procedure for regular and special meetings to fulfill the duties imposed upon it by this Chapter, consistent with Robert’s Rules of Order (10th Edition).
 - 2. Review all applications for Corridor Improvement Grants.
 - 3. Make recommendations to the City Council for approval of Corridor Improvement Grants.
 - 4. Advise the City Council on any matter pertaining to this Chapter and its enforcement, including, but not limited to, the following:
 - a. Amendments to this Chapter.
 - b. Policy concerning streetscape (both public and private streetscape).
 - c. Administration of the Corridor Improvement Grant Program.
- B. Coordination with other City Commissions. The recommendations and policies of the CIC shall complement the recommendations, decisions, and policies of the Plan Commission, Tree Commission

CITY CORRIDOR IMPROVEMENT PROGRAM

and Historic Preservation Commission. Any recommendations, proposed policy, or proposed work in conflict with other City Commissions shall be resolved by the City Council.
(Ord. 2009-M-8 § 1.)

12.40.050 Grant Application Procedure.

- A. Applications for Corridor Improvement Grants shall be made to the CIC by completing the application form available from the Community Development Department.
- B. The CIC shall evaluate all Grant applications based upon its ability to satisfy the goals and priorities of the CIC.
- C. The CIC shall consider all applications at one or more of its public meetings. The CIC shall render a decision to recommend approval or denial of the Grant application in a timely manner.
- D. The City Council shall consider the recommendations from the CIC in making decisions regarding approval of Grant applications.
- E. Grants shall be awarded to reimburse Grant Recipients for costs as set forth in this Ordinance.

(Ord. 2009-M-8 § 1; Ord. 2001-M-24 § 1.)

12.40.060 Corridor Improvement Agreements.

Grant Recipients shall execute a Corridor Improvement Agreement in a form satisfactory to the City. The terms of said Agreement shall include, but not limited to:

- A. The Corridor Improvement Grant shall only be used for Eligible Improvements.
 - 1. The Eligible Improvements shall exceed the minimum landscaping requirements of the St. Charles Zoning Ordinance (Title 17 of the City Code) and all other provisions of the City Code. In the event that an Eligible Property is subject to a Planned Unit Development (PUD), the proposed improvements must exceed the landscaping required by the applicable PUD landscape plan.
 - 2. In no event shall Corridor Improvement Grant funds be used for improvements that are required by the Zoning Ordinance or any other provision of the City Code.
 - 3. In no event shall Corridor Improvement Grant funds be used for permit or other fees imposed by a governmental entity.
- B. Eligible Improvements shall be completed in strict accordance with a landscaping plan approved by the CIC. Approved landscape plans shall comply with the City Code and the program description. The Director of Community Development may, at his or her discretion, approve minor revisions to said plan due to the unavailability of Landscape Materials, delayed due to weather, availability of materials or other circumstances beyond the reasonable control of Grant Recipients.
- C. Eligible Improvements shall be completed in a timely manner.
 - 1. All Eligible Improvements shall be completed within two hundred-seventy (270) calendar days of the execution of the Corridor Improvement Agreement. The City may, at its sole discretion, authorize an extension of up to two hundred-seventy (270) calendar days. In the event that the Eligible Improvements are not complete in the time provided by the Corridor Improvement Agreement (or extension thereof as the case may be) the City shall not be obligated to reimburse Grant Recipients after the date of expiration.
 - 2. Construction of the Eligible Improvements shall not commence prior to the execution of the Corridor Improvement Agreement; improvements constructed prior to the execution of said Agreement shall not be eligible for Grant funds.
- D. Disbursement procedures; reimbursement of costs.
 - 1. Upon completion of the Eligible Improvements, Grant Recipients shall submit copies of all design invoices, contractor's statements, other invoices, proof of payment and notarized final lien waivers to the Director of Community Development. Grant funds shall not be disbursed without supporting documentation.

CITY CORRIDOR IMPROVEMENT PROGRAM

2. Notwithstanding any other provision herein, the Director of Community Development may, at his or her discretion, authorize disbursement of Grant funds before the Eligible Improvements are completed if: (a) at least forty percent (40%) of the Eligible Improvements are constructed; and (b) design invoices, contractor's statements, other invoices, proof of payment, and notarized final lien waivers have been submitted; and (c) the completion of the remaining Eligible Improvements are delayed due to weather, unavailability of Landscaping Materials or other circumstances beyond the reasonable control of the Grant recipients.
- E. Grant Recipients shall maintain the Eligible Improvements without alteration for five (5) years after the execution of the Corridor Improvement Agreement. A restrictive covenant limiting alterations may be required by the City Council at the time of approval of the Corridor Improvement Agreement; the City Council may subsequently waive the requirement following a recommendation from the Corridor Improvement Commission and Director of Community development, upon submittal of evidence of hardship or unusual circumstances.
- F. Grant Recipients shall expressly acknowledge that Corridor Improvement Grants may be subject to Federal, State and local taxes and as such, they have consulted with their attorney or tax advisor. Grant Recipients shall provide the City with their social security or taxpayer identification number and such other information as may be required by the City.
- G. To the fullest extent permitted by law, Grant Recipients shall agree to indemnify, defend, protect and hold harmless the City. The terms of said indemnification and hold harmless shall be set forth in the Corridor Improvement Agreement.
- H. Grant Recipients shall purchase and maintain general liability insurance naming the City as additional insured party as set forth in the Corridor Improvement Agreement.
(Ord. 2009-M-8 § 1; Ord. 2001-M-24 §1.)

12.40.070 Funding Source.

The Corridor Improvement Program shall be funded by the City of St. Charles General Fund.
(Ord. 2009-M-8 § 1.)

Chapter 12.50

SPECIAL EVENTS

Sections:

- 12.50.010 Special Events Policy Established.
- 12.50.020 Special Events – Approval Required, Compliance with Policy.
- 12.50.030 Violation - Penalty.

12.50.010 Special Events Policy Established.

The corporate authorities shall adopt by ordinance, and may amend from time to time, a Special Events Policy. The Special Events Policy shall contain such terms, conditions and restrictions as the corporate authorities deem appropriate governing the approval and conduct of Special Events. The Special Events Policy, as amended from time to time, is expressly incorporated in this Section 12.50.010 by reference, as if set out in full. Copies of the Special Events Policy shall be kept on file in the office of Building and Code Enforcement.

(Ord. 2009-M-6 § 2.)

12.50.020 Special Events – Approval Required, Compliance with Policy.

It is unlawful for any person to conduct a Special Event within the corporate limits of the City, unless approval therefore has first been obtained in accordance with and as provided for in the Special Events Policy.

It is further unlawful for any person to conduct a Special Event in violation of any provision of the Special Events Policy.

(Ord. 2009-M-6 § 2.)

12.50.030 Violation – Penalty.

Any person, firm or corporation violating any provision of this Chapter shall, upon conviction, be fined not less than twenty-five dollars (\$25.00) nor more than five hundred dollars (\$500.00) for each offense. A separate offense shall be deemed committed on each day during or on which a violation occurs or continues.

(Ord. 2009-M-6 § 2.)

STREETLIGHT BANNERS

Chapter 12.60

STREETLIGHT BANNERS

Sections:

12.60.010	Streetlight Banners Policy Established
12.60.020	Streetlight Banners – Approval Required, Compliance with Policy
12.60.030	Violation - Penalty

12.60.010 Streetlight Banners Policy Established.

The corporate authorities shall adopt by ordinance, and may amend from time to time, a Streetlight Banners Policy. The Streetlight Banners Policy shall contain such terms, conditions and restrictions as the corporate authorities deem appropriate governing the approval and display of Streetlight Banners. The Streetlight Banners Policy, as amended from time to time, is expressly incorporated in this Section 12.60.010 by reference, as if set out in full. Copies of the Streetlight Banners Policy shall be kept on file in the office of Building and Code Enforcement.
(Ord. 2009-M-9 § 2.)

12.60.020 Streetlight Banners – Approval Required, Compliance with Policy.

It is unlawful for any person to display a Streetlight Banner within the corporate limits of the City, unless approval therefore has first been obtained in accordance with and as provided for in the Streetlight Banner Policy. It is further unlawful for any person to display a Streetlight Banner in violation of any provision of the Streetlight Banner Policy.
(Ord. 2009-M-9 § 2.)

12.60.030 Violation – Penalty.

Any person, firm or corporation violating any provision of this Chapter shall, upon conviction, be fined not less than twenty-five dollars (\$25.00) nor more than five hundred dollars (\$500.00) for each offense. A separate offense shall be deemed committed on each day during or on which a violation occurs or continues.
(Ord. 2009-M-9 § 2.)

TITLE 12 FOOTNOTES

TITLE 12 FOOTNOTES

1. For statutory provisions providing municipalities with general powers over streets and public ways, see 65 ILCS 5/11-80-1 et seq. (Ord. 1996-M-53 § 26.)
2. For statutory provisions authorizing municipalities to prescribe regulations for driveways, see 65 ILCS 5/11-30-8. (Ord. 1996-M-53 § 26.)
3. For statutory provisions authorizing cities to regulate the numbering of buildings and lots, see 65 ILCS 5/11-80-18. (Ord. 1996-M-53 § 26.)
4. For statutory provisions on municipal control of planting trees, see 65 ILCS 5/11-72-1; for provisions on municipal regulation of street advertising, see 65 ILCS 5/11-80-15. (Ord. 1996-M-53 § 26.)