

City of St. Charles

Swimming Pools (Above ground & In-ground) and Spas



Building & Code Enforcement Division
2 East Main Street
St. Charles IL 60174
630.377.4406 (Office)
630.443.4638 (Fax)
<http://www.stcharlesil.gov>

*Please direct any and all questions to the City of St. Charles Building & Code Enforcement Division:
Monday through Friday (8 AM to 4:30 PM) at 630.377.4406*

This is a summary of the City of St. Charles ordinances affecting Pool and Spa Construction. A building permit is required prior to any construction of a swimming pool (Above ground or in-ground) and spas that contain water over 24-inches. The following are guidelines and comments for obtaining a building permit.

Application and Drawings Procedures:

- ▶ An application is to be filled out and submitted to the Building Department. The contractors names, addresses, phone numbers and, if required, their license numbers are to be filled out when submitting the application.
- ▶ Two (2) sets of drawings showing the construction details for the pool or spa are to be submitted with the application. Include in these plans:
 - * Catalog specification sheet (NSF approval required)
 - * Anti-Vortex main drain
 - * Skimmer wells, pump, filter, lights, and heaters
 - * Diving board – slides
 - * Any other applicable equipment
 - * Electric plan (please see attachment)
- ▶ Two (2) copies of the plat of survey showing the measurements to lot lines drawn on the survey and indicate the location of:
 - * Pool – Spa
 - * Path of electric service to the house (see clearances)
 - * No pool or spa may be placed closer than five (5') feet to the lot line, or be located in an easement.
- ▶ Our goal is to complete the review for your building permit within 10 working days.

Application – Permit Fees: Payment is to be made in the form of check, cash, or money order.

- ⇒ A filing fee is to be paid at time of submission of application and drawings or plans.
 - **In-ground Pool** - **\$185.00**
 - **Above Ground Pool** - **\$55.00**
- ⇒ **Re-inspection fee.** During the construction of your project should you fail any of the required inspections there is a re-inspection charge. The fees are due prior to certificate of occupancy. The fee schedule is as follows;
 - \$65.00 per Building Department re-inspection for all types of inspections during construction (excluding finals)
 - \$85.00 per re-inspection for all residential final inspections.
- ⇒ **Temporary certificate of occupancies.** \$85.00 is due prior to issuance of a temporary certificate of occupancy for residential.

Barrier or Fencing:

- ⊗ Barrier placement - pool excavation must be protected during construction with approved fencing.
- ⊗ Permanent barrier or fencing must be in place prior to filling.
- ⊗ Silt fence required during construction.
- ⊗ A barrier or fence is to be constructed per the 2000 International Residential Code. A copy of the section of the code is attached for your information.
- ⊗ If a fence is installed, a Fence Release and Indemnity Agreement is to be completed and submitted with the application.
 - The Release and Indemnity Agreement is to be completed in black ink
 - The Release and Indemnity Agreement is to be notarized

Inspections:

The following is a list of inspections, which might be required for your project.

- Air test
- Underground Electric
- Plumbing
- Gas
- Concrete - Bonding
- Fence
- Final

Building Codes:

The following are the Building Codes, which the City of St. Charles has adopted:

- St. Charles Municipal Code
- 2009 Int'l Building Code w/revisions
- 2009 Int'l Mechanical Code w/revisions
- 2008 Nat'l Electrical Code w/revisions
- 2004 IL State Plbg Code w/revisions
- 2009 Int'l Residential Code/revisions
- 2009 Int'l Fire Prevention Code/revision
- 2009 Int'l Fuel Gas Code w/revisions

Energy Conservation Code for Swimming Pools and Spas (2009 Edition):

- 403.9.1 Pool heaters. All pool heaters shall be equipped with a readily accessible on-off switch to allow shutting off the heater without adjusting the thermostat setting. Pool heaters fired by natural gas shall not have continuously burning pilot lights.
- 403.9.2 Time switches. Time switches that can automatically turn off and on heaters and pumps according to a preset schedule shall be installed on swimming pool heaters and pumps.
 - Exceptions:
 - 1) Where public health standards require 24-hour pump operation.
 - 2) Where pumps are required to operate solar and waste heat recovery pool heating systems.
- 403.9.3 Pool Covers. Heated pools shall be equipped with a vapor-retardant pool cover on or at the water surface. Pools heated to more than 90-degrees shall have a pool cover with a minimum R-12.
 - Exception:
 - 1) Pools deriving over 60-percent of the energy from site-recovered energy or solar energy source.

Electric Requirements:

- The electric requirements are based upon the 2002 National Electric Code.
- Section 680.0 Overhead clearances:
 - 22-feet – 6-inches above water edge
 - 14-feet – 0-inches above any platform with in the pool and 10-feet each side of the pool
- Section 680.10 Underground Clearance:

- 5-feet horizontal from the inside of the pool wall or meet exceptions
- All boxes, covers, and fittings are to be weatherproof outdoor type and sunlight resistant.
- Section 680.10 Minimum burial depth of electric to pool as follows rigid metal conduit 6-inches, intermediate metal conduit 6-inches, nonmetallic PVC 18-inches, and should be listed for electric (gray in color) direct burial cable 24-inches with rigid sleeve from elbow up.
- All motors shall be listed and labeled per 110-3(B) UL or equivalent by an approved testing agency to the U.S. standards.
- Section 680.21 (B) For all non-double insulated pump motors, a bond is required to the motor housing, the pool frame, and all metal conduits.
- Section 680.22(A)(1) 5-foot minimum 10-foot maximum to receptacle that provides power to pool equipment and consist of single receptacle, locking configuration (twist lock), grounding type, and GFCI protection.
- Section 680.26 (4) #8 Solid copper wire to bond all metal parts 5-foot horizontally away from inside of pool wall (plastic pool with metal top ring requires bonding) by pressure connectors or clamps labeled as being suitable for the purpose. (See section)
- Section 680.22(2)(3) General – purpose receptacle required 10-foot – 20-foot from the inside wall of the pool, may be on house GFI.
- Section 680.12 Maintenance disconnect (switch) required to be accessible and within sight of its equipment.
- Section 680.21(5) Cord and plug connection on motors shall not exceed 3-feet in length.
- Section 680.7 Grounding of all electric equipment per 250.122 not to be smaller than 12 AWG to include wall lighting and underwater luminaries, electric equipment within 5-feet of inside wall of pool, electric equipment associated with recirculating system, junction boxes, transformer enclosures, ground fault circuit interrupters, panel boards that are not part of the service equipment and that supply any electrical equipment associated with the pool.

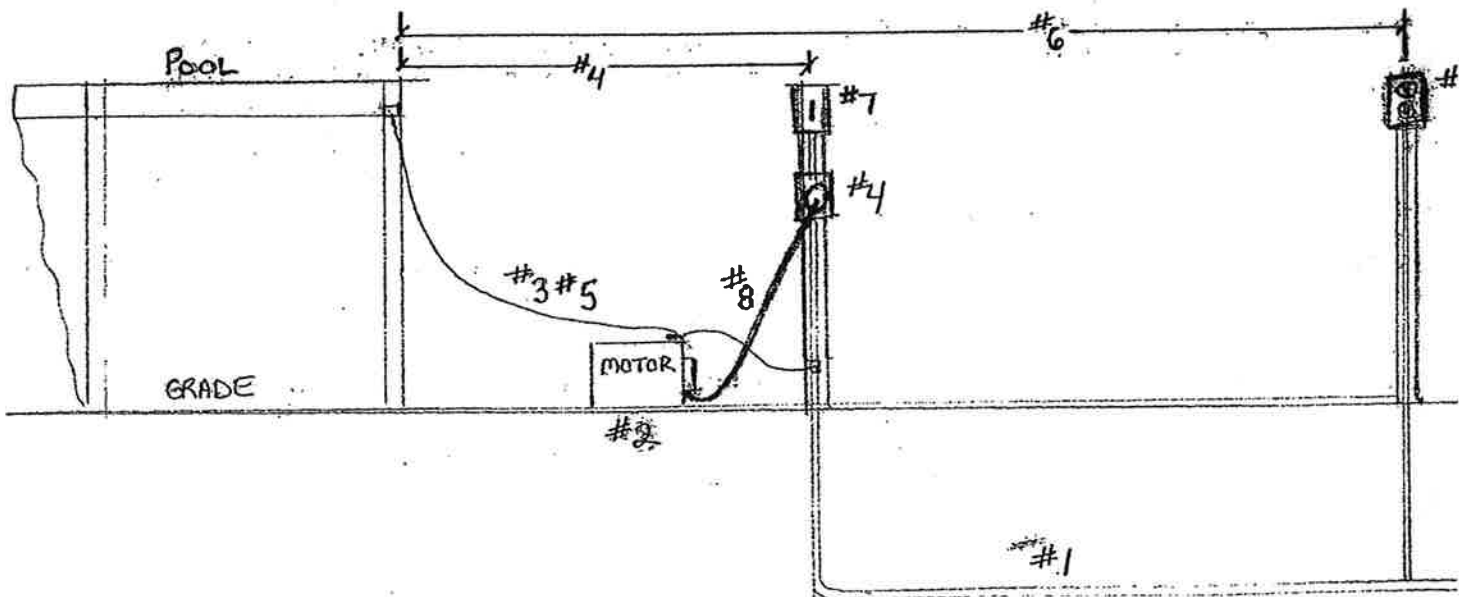

Homeowner – Contractor Responsibilities:

- ✓ It is the responsibility of the homeowner/contractor to schedule with the Building Department the required inspections. The required inspections are indicated on the Plan Review form, which is attached to your permit and the Field Copy of drawings. When calling to schedule an inspection, please have the address and the permit number.
- ✓ Inspections shall be called a minimum of 24 hours before they become due.
- ✓ Call J.U.I.L.E. (Joint Underground Location for Inspectors and Engineers) at least 48-hours prior to any digging to locate any underground utilities. **(1-800/892-0123)**

- Electric Utilities	Red	- Sewer Utilities	Green
- Comcast (Cable)	Orange	- Telephone Utilities	Orange
- Northern Illinois Gas (NICOR)	Yellow	- Water Utilities	Blue

APPENDIX G

SWIMMING POOLS, SPAS AND HOT TUBS

(The provisions contained in this appendix are not mandatory unless specifically referenced in the adopting ordinance.)

SECTION AG101 GENERAL

AG101.1 General. The provisions of this appendix shall control the design and construction of swimming pools, spas and hot tubs installed in or on the *lot* of a one- or two-family dwelling.

AG101.2 Pools in flood hazard areas. Pools that are located in flood hazard areas established by Table R301.2(1), including above-ground pools, on-ground pools and in-ground pools that involve placement of fill, shall comply with Sections AG101.2.1 or AG101.2.2.

Exception: Pools located in riverine flood hazard areas which are outside of designated floodways.

AG101.2.1 Pools located in designated floodways. Where pools are located in designated floodways, documentation shall be submitted to the *building official*, which demonstrates that the construction of the pool will not increase the design flood elevation at any point within the *jurisdiction*.

AG101.2.2 Pools located where floodways have not been designated. Where pools are located where design flood elevations are specified but floodways have not been designated, the applicant shall provide a floodway analysis that demonstrates that the proposed pool will not increase the design flood elevation more than 1 foot (305 mm) at any point within the *jurisdiction*.

SECTION AG102 DEFINITIONS

AG102.1 General. For the purposes of these requirements, the terms used shall be defined as follows and as set forth in Chapter 2.

ABOVE-GROUND/ON-GROUND POOL. See "Swimming pool."

BARRIER. A fence, wall, building wall or combination thereof which completely surrounds the swimming pool and obstructs access to the swimming pool.

HOT TUB. See "Swimming pool."

IN-GROUND POOL. See "Swimming pool."

RESIDENTIAL. That which is situated on the premises of a detached one- or two-family dwelling or a one-family *townhouse* not more than three stories in height.

SPA, NONPORTABLE. See "Swimming pool."

SPA, PORTABLE. A nonpermanent structure intended for recreational bathing, in which all controls, water-heating and water-circulating *equipment* are an integral part of the product.

SWIMMING POOL. Any structure intended for swimming or recreational bathing that contains water over 24 inches (610

mm) deep. This includes in-ground, above-ground and on-ground swimming pools, hot tubs and spas.

SWIMMING POOL, INDOOR. A swimming pool which is totally contained within a structure and surrounded on all four sides by the walls of the enclosing structure.

SWIMMING POOL, OUTDOOR. Any swimming pool which is not an indoor pool.

SECTION AG103 SWIMMING POOLS

AG103.1 In-ground pools. In-ground pools shall be designed and constructed in conformance with ANSI/NSPI-5 as listed in Section AG108.

AG103.2 Above-ground and on-ground pools. Above-ground and on-ground pools shall be designed and constructed in conformance with ANSI/NSPI-4 as listed in Section AG108.

AG103.3 Pools in flood hazard areas. In flood hazard areas established by Table R301.2(1), pools in coastal high hazard areas shall be designed and constructed in conformance with ASCE 24.

SECTION AG104 SPAS AND HOT TUBS

AG104.1 Permanently installed spas and hot tubs. Permanently installed spas and hot tubs shall be designed and constructed in conformance with ANSI/NSPI-3 as listed in Section AG108.

AG104.2 Portable spas and hot tubs. Portable spas and hot tubs shall be designed and constructed in conformance with ANSI/NSPI-6 as listed in Section AG108.

SECTION AG105 BARRIER REQUIREMENTS

AG105.1 Application. The provisions of this chapter shall control the design of barriers for residential swimming pools, spas and hot tubs. These design controls are intended to provide protection against potential drownings and near-drownings by restricting access to swimming pools, spas and hot tubs.

AG105.2 Outdoor swimming pool. An outdoor swimming pool, including an in-ground, above-ground or on-ground pool, hot tub or spa shall be surrounded by a barrier which shall comply with the following:

1. The top of the barrier shall be at least 48 inches (1219 mm) above *grade* measured on the side of the barrier which faces away from the swimming pool. The maximum vertical clearance between grade and the bottom of

the barrier shall be 2 inches (51 mm) measured on the side of the barrier which faces away from the swimming pool. Where the top of the pool structure is above grade, such as an above-ground pool, the barrier may be at ground level, such as the pool structure, or mounted on top of the pool structure. Where the barrier is mounted on top of the pool structure, the maximum vertical clearance between the top of the pool structure and the bottom of the barrier shall be 4 inches (102 mm).

2. Openings in the barrier shall not allow passage of a 4-inch-diameter (102 mm) sphere.
3. Solid barriers which do not have openings, such as a masonry or stone wall, shall not contain indentations or protrusions except for normal construction tolerances and tooled masonry joints.
4. Where the barrier is composed of horizontal and vertical members and the distance between the tops of the horizontal members is less than 45 inches (1143 mm), the horizontal members shall be located on the swimming pool side of the fence. Spacing between vertical members shall not exceed $1\frac{3}{4}$ inches (44 mm) in width. Where there are decorative cutouts within vertical members, spacing within the cutouts shall not exceed $1\frac{3}{4}$ inches (44 mm) in width.
5. Where the barrier is composed of horizontal and vertical members and the distance between the tops of the horizontal members is 45 inches (1143 mm) or more, spacing between vertical members shall not exceed 4 inches (102 mm). Where there are decorative cutouts within vertical members, spacing within the cutouts shall not exceed $1\frac{3}{4}$ inches (44 mm) in width.
6. Maximum mesh size for chain link fences shall be a $2\frac{1}{4}$ -inch (57 mm) square unless the fence has slats fastened at the top or the bottom which reduce the openings to not more than $1\frac{3}{4}$ inches (44 mm).
7. Where the barrier is composed of diagonal members, such as a lattice fence, the maximum opening formed by the diagonal members shall not be more than $1\frac{3}{4}$ inches (44 mm).
8. Access gates shall comply with the requirements of Section AG105.2, Items 1 through 7, and shall be equipped to accommodate a locking device. Pedestrian access gates shall open outward away from the pool and shall be self-closing and have a self-latching device. Gates other than pedestrian access gates shall have a self-latching device. Where the release mechanism of the self-latching device is located less than 54 inches (1372 mm) from the bottom of the gate, the release mechanism and openings shall comply with the following:
 - 8.1. The release mechanism shall be located on the pool side of the gate at least 3 inches (76 mm) below the top of the gate; and

- 8.2. The gate and barrier shall have no opening larger than $\frac{1}{2}$ inch (12.7 mm) within 18 inches (457 mm) of the release mechanism.

9. Where a wall of a *dwelling* serves as part of the barrier, one of the following conditions shall be met:
 - 9.1. The pool shall be equipped with a powered safety cover in compliance with ASTM F 1346; or
 - 9.2. Doors with direct access to the pool through that wall shall be equipped with an alarm which produces an audible warning when the door and/or its screen, if present, are opened. The alarm shall be listed and *labeled* in accordance with UL 2017. The deactivation switch(es) shall be located at least 54 inches (1372 mm) above the threshold of the door; or
 - 9.3. Other means of protection, such as self-closing doors with self-latching devices, which are *approved* by the governing body, shall be acceptable as long as the degree of protection afforded is not less than the protection afforded by Item 9.1 or 9.2 described above.
10. Where an above-ground pool structure is used as a barrier or where the barrier is mounted on top of the pool structure, and the means of access is a ladder or steps:
 - 10.1. The ladder or steps shall be capable of being secured, locked or removed to prevent access; or
 - 10.2. The ladder or steps shall be surrounded by a barrier which meets the requirements of Section AG105.2, Items 1 through 9. When the ladder or steps are secured, locked or removed, any opening created shall not allow the passage of a 4-inch-diameter (102 mm) sphere.

AG105.3 Indoor swimming pool. Walls surrounding an indoor swimming pool shall comply with Section AG105.2, Item 9.

AG105.4 Prohibited locations. Barriers shall be located to prohibit permanent structures, *equipment* or similar objects from being used to climb them.

AG105.5 Barrier exceptions. Spas or hot tubs with a safety cover which complies with ASTM F 1346, as listed in Section AG107, shall be exempt from the provisions of this appendix.

SECTION AG106 ENTRAPMENT PROTECTION FOR SWIMMING POOL AND SPA SUCTION OUTLETS

AG106.1 General. Suction outlets shall be designed and installed in accordance with ANSI/APSP-7.

SECTION AG107 ABBREVIATIONS

AG107.1 General.

ANSI—American National Standards Institute
11 West 42nd Street
New York, NY 10036

APSP—Association of Pool and Spa Professionals
NSPI—National Spa and Pool Institute
2111 Eisenhower Avenue
Alexandria, VA 22314

ASCE—American Society of Civil Engineers
1801 Alexander Bell Drive
Reston, VA 98411-0700

ASTM—ASTM International
100 Barr Harbor Drive,
West Conshohocken, PA 19428

UL—Underwriters Laboratories, Inc.
333 Pfingsten Road
Northbrook, IL 60062-2096

SECTION AG108 STANDARDS

AG108.1 General.

ANSI/NSPI

ANSI/NSPI-3-99 Standard for
Permanently Installed Residential Spas AG104.1

ANSI/NSPI-4-99 Standard for Above-ground/
On-ground Residential Swimming Pools AG103.2

ANSI/NSPI-5-2003 Standard for
Residential In-ground Swimming Pools. AG103.1

ANSI/NSPI-6-99 Standard for
Residential Portable Spas AG104.2

ANSI/APSP

ANSI/APSP-7-06 Standard for Suction Entrapment
avoidance in Swimming Pools, Wading Pools, Spas,
Hot Tubs and Catch Basins. AG106.1

ASCE

ASCE/SEI-24-05 Flood Resistant
Design and Construction AG103.3

ASTM

ASTM F 1346-91 (2003) Performance
Specification for Safety Covers and Labeling
Requirements for All Covers for Swimming Pools,
Spas and Hot Tubs AG105.2, AG105.5

UL

UL 2017-2000 Standard for General-purpose
Signaling Devices and Systems—with Revisions
through June 2004. AG105.2

SAFETY BARRIER GUIDELINES FOR HOME POOLS

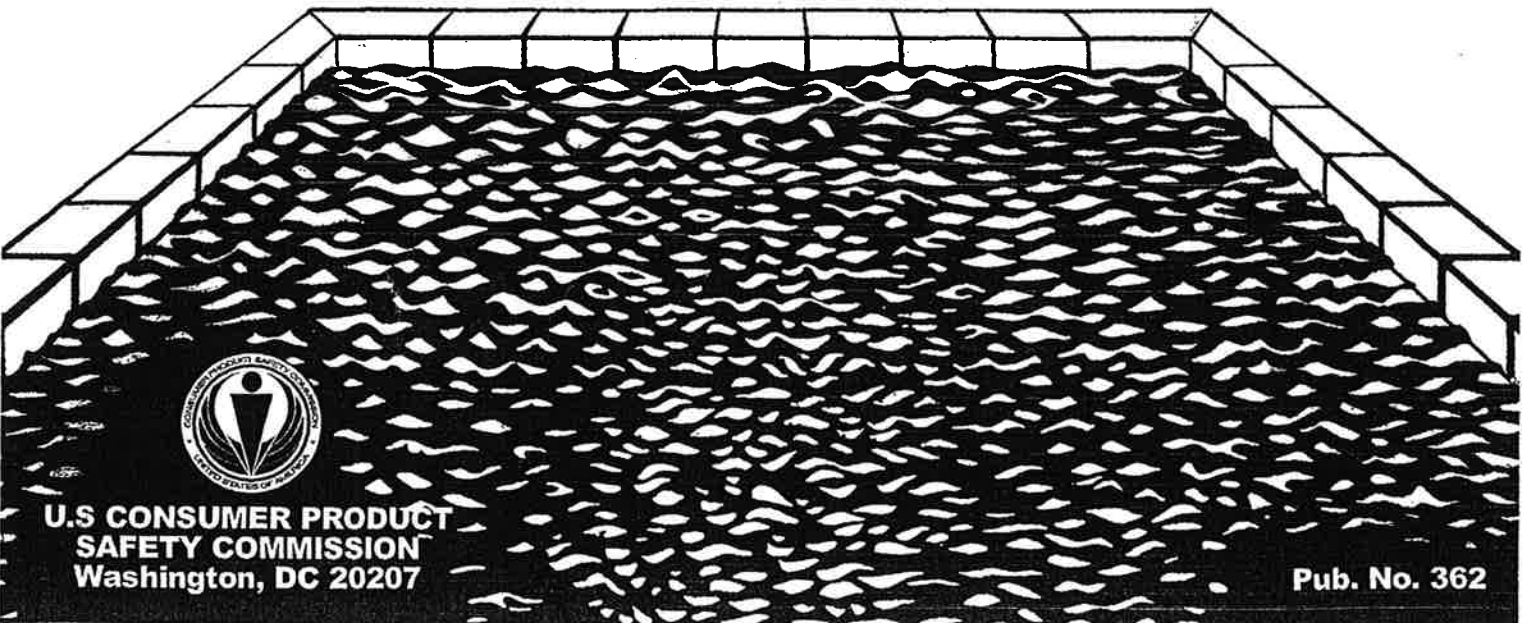
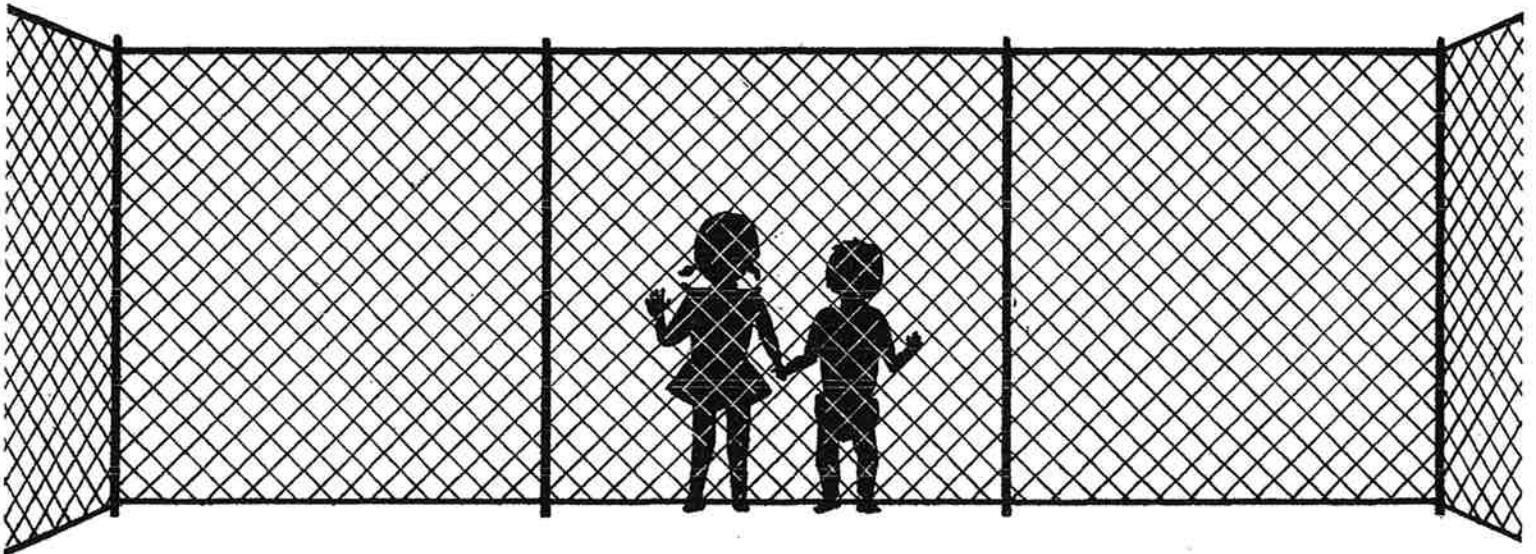

U.S. CONSUMER PRODUCT
SAFETY COMMISSION
Washington, DC 20207

Pub. No. 362

Swimming pools should always be happy places. Unfortunately, each year thousands of American families confront swimming pool tragedies—drownings and near-drownings of young children. These tragedies are preventable. This U.S. Consumer Product Safety Commission (CPSC) handbook offers guidelines for pool barriers that can help prevent most submersion incidents involving young children.

This handbook is designed for use by owners, purchasers, and builders of residential pools, spas, and hot tubs.

The swimming pool barrier guidelines are not a CPSC standard and are not mandatory requirements. Therefore, the Commission does not endorse these guidelines as the sole method to minimize pool drownings of young children. The Commission believes, however, that the safety features recommended in this handbook will help make pools safer. Publication of this handbook is expected to promote pool safety awareness among owners, purchasers and builders of swimming pools.

Some localities have incorporated the guidelines in this handbook into their building codes. Check with your local authorities to see whether these guidelines are included in your area's building code or in other regulations.



Why the Swimming Pool Guidelines Were Developed

Each year, hundreds of young children die and thousands come close to death due to submersion in residential swimming pools. CPSC has estimated that each year about 300 children under 5 years old drown in swimming pools. The Commission estimates hospital emergency room treatment is required for more than 2,000 children under 5 years of age who were submerged in residential pools.

CPSC did an extensive study of swimming pool accidents, both fatal drownings and near-fatal submersions, in California, Arizona and Florida, states in which home swimming pools are very popular and in use during much of the year. The findings from that study led Commission staff to develop the guidelines in this handbook.

- In California, Arizona and Florida, drowning was the leading cause of accidental death in and around the home for children under the age of 5 years.
- 75 percent of the children involved in swimming pool submersion or drowning accidents were between 1 and 3 years old.
- Boys between 1 and 3 years old were the most likely victims of fatal drownings and near-fatal submersions in residential swimming pools.
- Most of the victims were being supervised by one or both parents when the swimming pool accident occurred.
- Nearly half of the child victims were last seen in the house before the pool accident occurred. In addition, 23 percent of the accident victims were last seen on the porch or patio, or in the yard.
- This means that fully 69 percent of the children who became victims in swimming pool accidents were not expected to be in or at the pool, but were found drowned or submerged in the water.
- 65 percent of the accidents occurred in a pool owned by the victim's immediate family, and 33 percent of the accidents occurred in pools owned by relatives or friends.
- Fewer than 2 percent of the pool accidents were a result of children trespassing on property where they didn't live or belong.
- 77 percent of the swimming pool accident victims had been missing for five minutes or less when they were found in the pool drowned or submerged.

The speed with which swimming pool drownings and submersions can occur is a special concern: by the time a child's absence is noted, the child may have drowned. Anyone who has cared for a toddler knows how fast young children can move. Toddlers are inquisitive and impulsive and lack a realistic sense of danger. These behaviors, coupled with a child's ability to move quickly and unpredictably make swimming pools particularly hazardous for households with young children.

Swimming pool drownings of young children have another particularly insidious feature: these are silent deaths. It is unlikely that splashing or screaming will occur to alert a parent or caregiver that a child is in trouble.

CPSC staff have reviewed a great deal of data on drownings and child behavior, as well as information on pool and pool barrier construction. The staff concluded that the best way to reduce child drownings in residential pools was for pool owners to construct and maintain barriers that would prevent young children from gaining access to pools. However, there are no substitutes for diligent supervision.

The Swimming Pool Barrier Guidelines

How to Prevent a Child from Getting OVER a Pool Barrier

This section explains the CPSC swimming pool barrier guidelines with illustrated descriptions of pool barriers. Definitions of terms used in the guidelines are provided on page 6.

The definition of pool includes spas and hot tubs; the swimming pool barrier guidelines therefore apply to these structures as well as to conventional swimming pools.

A successful pool barrier prevents a child from getting OVER, UNDER, or THROUGH and keeps the child from gaining access to the pool except when supervising adults are present.

A young child can get over a pool barrier if the barrier is too low or if the barrier has handholds or footholds for a child to use when climbing.

The guidelines recommend that the top of a pool barrier be at least 48 inches above grade, measured on the side of the barrier which faces away from the swimming pool.



Guidelines recommend eliminating handholds and footholds and minimizing the size of openings in a barrier's construction.

For a Solid Barrier:

No indentations or protrusions should be present, other than normal construction tolerances and masonry joints.

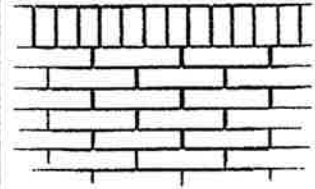

For a Barrier (Fence) Made Up of Horizontal and Vertical Members:

If the distance between the tops of the horizontal members is less than 45 inches, the horizontal members should be on the swimming pool side of the fence. The spacing of the vertical members should not exceed 1-3/4 inches. This size is based on the foot width of a young child and is intended to reduce the potential for a child to gain a foothold. If there are any decorative cutouts in the fence, the space within the cutouts should not exceed 1-3/4 inches.

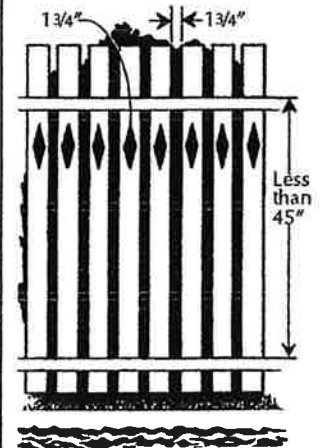

If the distance between the tops of the horizontal members is **more** than 45 inches, the horizontal members can be on the side of the fence facing away from the pool. The spacing between vertical members should not exceed 4 inches. This size is based on the head breadth and chest depth of a young child and is intended to prevent a child from passing through an opening. Again, if there are any decorative cutouts in the fence, the space within the cutouts should not exceed 1-3/4 inches.

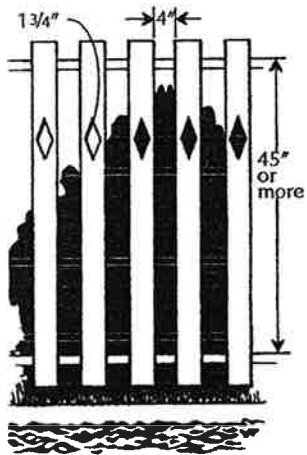

For a Chain Link Fence:

The mesh size should not exceed 1-1/4 inches square unless slats, fastened at the top or bottom of the fence, are used to reduce mesh openings to no more than 1-3/4 inches.

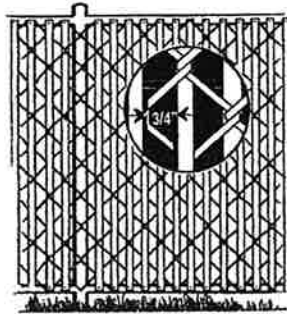
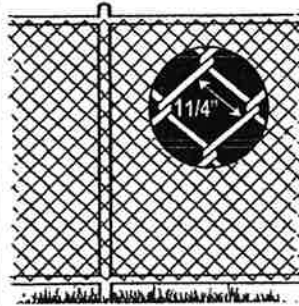

For a Fence Made Up of Diagonal Members (Latticework):

The maximum opening in the lattice should not exceed 1-3/4 inches.

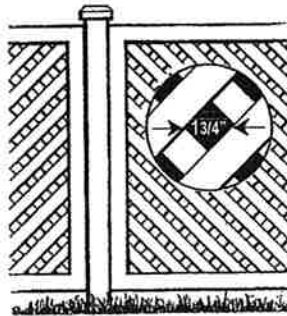

For Aboveground Pools:

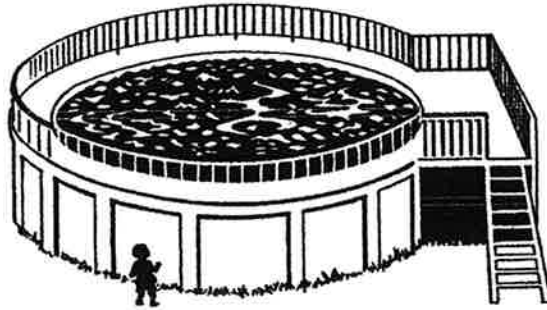

Aboveground pools should have barriers. The pool structure itself serves as a barrier or a barrier is mounted on top of the pool structure.

Then, there are two possible ways to prevent young children from climbing up into an aboveground pool. The steps or ladder can be designed to be secured, locked or removed to prevent access, or the steps or ladder can be surrounded by a barrier such as those described above.

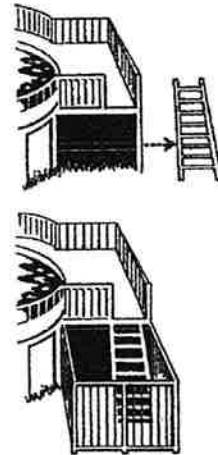

How to Prevent a Child from Getting UNDER a Pool Barrier

For any pool barrier, the maximum clearance at the bottom of the barrier should not exceed 4 inches above grade, when the measurement is done on the side of the barrier facing away from the pool.

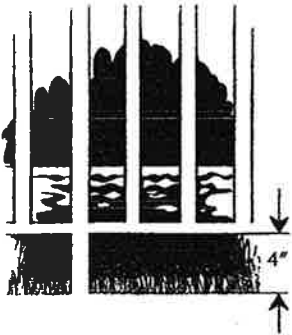

Aboveground Pool with Barrier on Top of Pool:

If an aboveground pool has a barrier on the top of the pool, the maximum vertical clearance between the top of the pool and the bottom of the barrier should not exceed 4 inches.

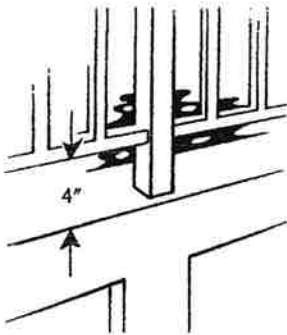

How to Prevent a Child from Getting THROUGH a Pool Barrier

Preventing a child from getting through a pool barrier can be done by restricting the sizes of openings in a barrier and by using self-closing and self-latching gates.

To prevent a young child from getting through a fence or other barrier, all openings should be small enough so that a 4-inch diameter sphere cannot pass through. This size is based on the head breadth and chest depth of a young child.



Gates:

There are two kinds of gates which might be found on a residential property. Both can play a part in the design of a swimming pool barrier.

Pedestrian Gates:

These are the gates people walk through. Swimming pool barriers should be equipped with a gate or gates which restrict access to the pool. A locking device should be included in the gate design. Gates should open out from the pool and should be self-closing and self-latching. If a gate is properly designed, even if the gate is not completely latched, a young child pushing on the gate in order to enter the pool area will at least close the gate and may actually engage the latch.



When the release mechanism of the self-latching device is less than 54 inches from the bottom of the gate, the release mechanism for the gate should be at least 3 inches below the top of the gate on the side facing the pool. Placing the release mechanism at this height prevents a young child from reaching over the top of a gate and releasing the latch.

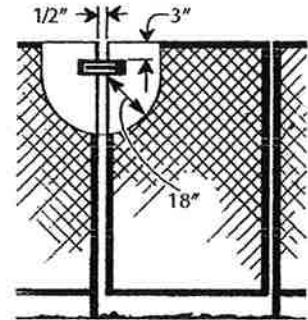

Also, the gate and barrier should have no opening greater than 1/2 inch within 18 inches of the latch release mechanism. This prevents a young child from reaching through the gate and releasing the latch.

All Other Gates (Vehicle Entrances, Etc.):

Other gates should be equipped with self-latching devices. The self-latching devices should be installed as described for pedestrian gates.

When the House Wall Forms Part of the Pool Barrier:

In many homes, doors open directly onto the pool area or onto a patio which leads to the pool.



In such cases, the wall of the house is an important part of the pool barrier, and passage through any doors in the house wall should be controlled by security measures. The importance of controlling a young child's movement from house to pool is demonstrated by the statistics obtained during CPSC's study of pool incidents in California, Arizona and Florida: almost half (46 percent) of the children who became victims of pool accidents were last seen in the house just before they were found in the pool.

All doors which give access to a swimming pool should be equipped with an audible alarm which sounds when the door and/or screen are opened. The alarm should sound for 30 seconds or more **within 7 seconds** after the door is opened. *Alarms should*

meet the requirements of UL 2017 General-Purpose Signaling Devices and Systems, Section 77.

The alarm should be loud: at least 85 dBA (decibels) when measured 10 feet away from the alarm mechanism. The alarm sound should be distinct from other sounds in the house, such as the telephone, doorbell and smoke alarm. The alarm should have an automatic reset feature.

Because adults will want to pass through house doors in the pool barrier without setting off the alarm, the alarm should have a switch that allows adults to temporarily deactivate the alarm for up to 15 seconds. The deactivation switch could be a touchpad (keypad) or a manual switch, and should be located at least 54 inches above the threshold of the door covered by the alarm. This height was selected based on the reaching ability of young children.

Power safety covers can be installed on pools to serve as security barriers. Power safety covers should conform to the specifications in ASTM F 1346-91. This standard specifies safety performance requirements for pool covers to protect young children from drowning.

If you wish further information on this standard, contact ASTM, Inc., Philadelphia, Pa. (formerly the American Society for Testing & Materials), directly.

Self-closing doors with self-latching devices could also be used to safeguard

doors which give ready access to a swimming pool.

Indoor Pools:

When a pool is located completely within a house, the walls that surround the pool should be equipped to serve as pool safety barriers. Measures recommended above where a house wall serves as part of a safety barrier also apply for all the walls surrounding an indoor pool.

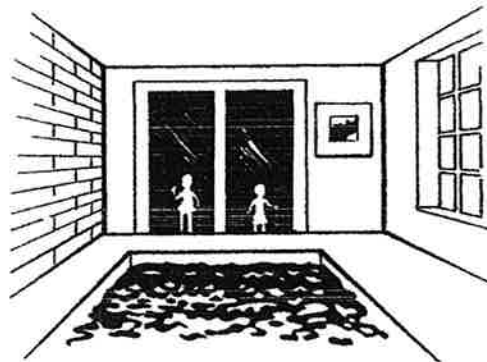

Barriers for Residential Swimming Pool, Spas, and Hot Tubs

The preceding explanations of the U.S. Consumer Product Safety Commission's pool barrier guidelines were provided in order to make it easier for pool owners, purchasers, builders, technicians and others to understand and apply the guidelines themselves. Detailed guidelines follow. Reading the following guidelines in conjunction with the diagrams previously provided may be especially helpful. For further information, consult your local building department or code authority.

Application

The guidelines presented in this document are intended to provide a means of protection against potential drownings and near-drownings to children under 5 years of age by restricting access to residential swimming pools, spas, and hot tubs.

Definitions

Aboveground/onground pool. See definition of swimming pool.

Barrier. A fence, a wall, a building wall or a combination thereof which completely surrounds the swimming pool and obstructs access to the swimming pool.

Hot tub. See definition of swimming pool.

Inground pool. See definition of swimming pool.

Residential. That which is situated on the premises of a detached one- or two-family dwelling or a one-family townhouse not more than three stories in height.

Spa, nonportable. See definition of swimming pool.

Spa, portable. A non-permanent structure intended for recreational bathing, in which all controls, water- heating, and water-circulating equipment are an integral part of the product and which is cord-connected (not permanently electrically wired).

Swimming pool. Any structure intended for swimming or recreational bathing that contains water over 24 inches deep. This includes inground, above-ground, and onground swimming pools, hot tubs, and spas.

Swimming pool, indoor. A swimming pool which is totally contained within a structure and surrounded on all four sides by walls of said structure.

Swimming pool, outdoor. Any swimming pool which is not an indoor pool.

Guidelines

Section I. Outdoor Swimming Pool

An outdoor swimming pool, including an inground, aboveground, or onground pool, hot tub, or spa, should be provided with a barrier which complies with the following:

1. The top of the barrier should be at least 48 inches above grade measured on the side of the barrier which faces away from the swimming pool. The maximum vertical clearance between grade and the bottom of the barrier should be 4 inches measured on the side of the barrier which faces away from the swimming pool. Where the top of the pool structure is above grade, such as an aboveground pool, the barrier may be at ground level, such as the pool structure, or mounted on top of the pool structure. Where the barrier is mounted on top of the pool structure, the maximum vertical clearance between the top of the pool structure and the bottom of the barrier should be 4 inches.
2. Openings in the barrier should not allow passage of a 4-inch diameter sphere.
3. Solid barriers, which do not have openings, such as a masonry or stone wall, should not contain indentations or protrusions except for normal construction tolerances and tooled masonry joints.

4. Where the barrier is composed of horizontal and vertical members and the distance between the tops of the horizontal members is less than 45 inches, the horizontal members should be located on the swimming pool side of the fence. Spacing between vertical members should not exceed 1-3/4 inches in width. Where there are decorative cutouts, spacing within the cutouts should not exceed 1-3/4 inches in width.

5. Where the barrier is composed of horizontal and vertical members and the distance between the tops of the horizontal members is 45 inches or more, spacing between vertical members should not exceed 4 inches. Where there are decorative cutouts, spacing within the cutouts should not exceed 1-3/4 inches in width.

6. Maximum mesh size for chain link fences should not exceed 1-3/4 inch square unless the fence is provided with slats fastened at the top or the bottom which reduce the openings to no more than 1-3/4 inches.

7. Where the barrier is composed of diagonal members, such as a lattice fence, the maximum opening formed by the diagonal members should be no more than 1-3/4 inches.

8. Access gates to the pool should comply with Section I, Paragraphs 1 through 7, and should be equipped to accommodate a locking device. Pedestrian access gates should open outward, away from the pool, and should be self-closing and have a self-latching device. Gates other than pedestrian access gates should have a self-latching device. Where the release mechanism of the self-latching device is located less than 54 inches from the bottom of the gate, (a) the release mechanism should be located on the pool side of the gate at least 3 inches below the top of the gate

and (b) the gate and barrier should have no opening greater than 1/2 inch within 18 inches of the release mechanism.

9. Where a wall of a dwelling serves as part of the barrier, one of the following should apply:

(a) All doors with direct access to the pool through that wall should be equipped with an alarm which produces an audible warning when the door and its screen, if present, are opened. The alarm should sound continuously for a minimum of 30 seconds **within 7 seconds** after the door is opened. *Alarms should meet the requirements of UL 2017 General-Purpose Signaling Devices and Systems, Section 77.* The alarm should have a minimum sound pressure rating of 85 dBA at 10 feet and the sound of the alarm should be distinctive from other household sounds, such as smoke alarms, telephones, and door bells. The alarm should automatically reset under all conditions. The alarm should be equipped with manual means, such as touchpads or switches, to temporarily deactivate the alarm for a single opening of the door from either direction. Such deactivation should last for no more than 15 seconds. The deactivation touchpads or switches should be located at least 54 inches above the threshold of the door.

(b) The pool should be equipped with a power safety cover which complies with ASTM F1346-91 listed below.

(c) Other means of protection, such as self-closing doors with self-latching devices, are acceptable so long as the degree of protection afforded is not less than the protection afforded by (a) or (b) described above.

10. Where an aboveground pool structure is used as a barrier or where the barrier is

mounted on top of the pool structure, and the means of access is a ladder or steps, then (a) the ladder to the pool or steps should be capable of being secured, locked or removed to prevent access, or (b) the ladder or steps should be surrounded by a barrier which meets Section I, Paragraphs 1 through 9. When the ladder or steps are secured, locked, or removed, any opening created should not allow the passage of a 4-inch diameter sphere.

Section II. Indoor Swimming Pool.

All walls surrounding an indoor swimming pool should comply with Section I, Paragraph 9.

Section III. Barrier Locations.

Barriers should be located so as to prohibit permanent structures, equipment or similar objects from being used to climb the barriers.

Exemptions

A portable spa with a safety cover which complies with ASTM F1346-91 listed below should be exempt from the guidelines presented in this document. But, swimming pools, hot tubs, and non-portable spas with safety covers should **not** be exempt from the provisions of this document.

ASTM F1346-91. Standard Performance Specification for Safety Covers and Labeling Requirements for All Covers for Swimming Pools, Spas and Hot Tubs.

DO NOT WRITE OR MARK ABOVE THE LINE
Use Black Ink Only

Release and Indemnity Agreement
For Fences Located in Utility and Drainage Easements in the City of St. Charles

Name of Record Owner (s) _____

Fence Building Permit (s) _____

Address of Property _____

Legal description of the property:

CITY OF ST CHARLES
Application for Building Permit



Department: Building & Code Enforcement Division

Phone: (630) 377-4406 Fax (630) 443-4638

Application Date: _____ Parcel No. _____ Permit No. _____

PLEASE PRINT ALL INFORMATION

I, _____, do hereby apply for a permit for the following described work

located at _____ Estimated Cost: _____

Description of proposed work: _____

Check List for Submittal of Application:

- Is your property located in the Historic Preservation District? Yes/No If yes, your application will need to be approved by the Historic Preservation Committee.
- Building Permit Application – Completely Filled Out.
- Two sets of construction details on the swimming pool that include information on the filtering system are to submitted.
- Two copies of the Plat of Survey with the pool drawn on the survey showing all measurements are to submitted.
- If a fence is being installed and is part of this submittal you will need the details on the fence, the height, style, and information on the locks on the gates.
- If the fence is being submitted separately, please refer to the Information Packet on Fencing.

Owner of the Property:

Name: _____

Address: _____

City/State/Zip Code: _____

Telephone NO. _____

Applicant:

Name: _____

Address: _____

City/State/Zip Code: _____

Telephone NO. _____

General Contractor:

Name: _____

Address: _____

City/State/Zip Code: _____

Telephone NO. _____

Illinois License No. _____

Contractor: _____

Name: _____

Address: _____

City/State/Zip Code: _____

Telephone NO. _____

Illinois License No. _____

I, the undersigned, certify that if a permit is issued to me, I will comply with all provisions of the building, plumbing, electric and other applicable ordinances of the City of St. Charles and shall perform all work, or cause all work to be performed according to the provisions of said ordinances. I, or my agent, shall personally supervise the work and shall do, or cause to have done, said work according to plans, specifications and other written information supplied as a part of this application. I am familiar with the applicable ordinances and the provision thereof and in signing this application do willingly become responsible for all work accomplished under the permit by all contractors, tradesmen and workmen, and shall call for inspections as required at a minimum of 24-hours before they become due.

PRINT NAME: _____ **SIGNATURE:** _____

REPORT OF THE BUILDING OFFICIAL

Accepted: _____ **Rejected:** _____ **Date:** _____

Signed: _____

For Office Use	
Received	_____
Fee Paid \$	_____
Check #	_____