

## DEPRESSED CURB

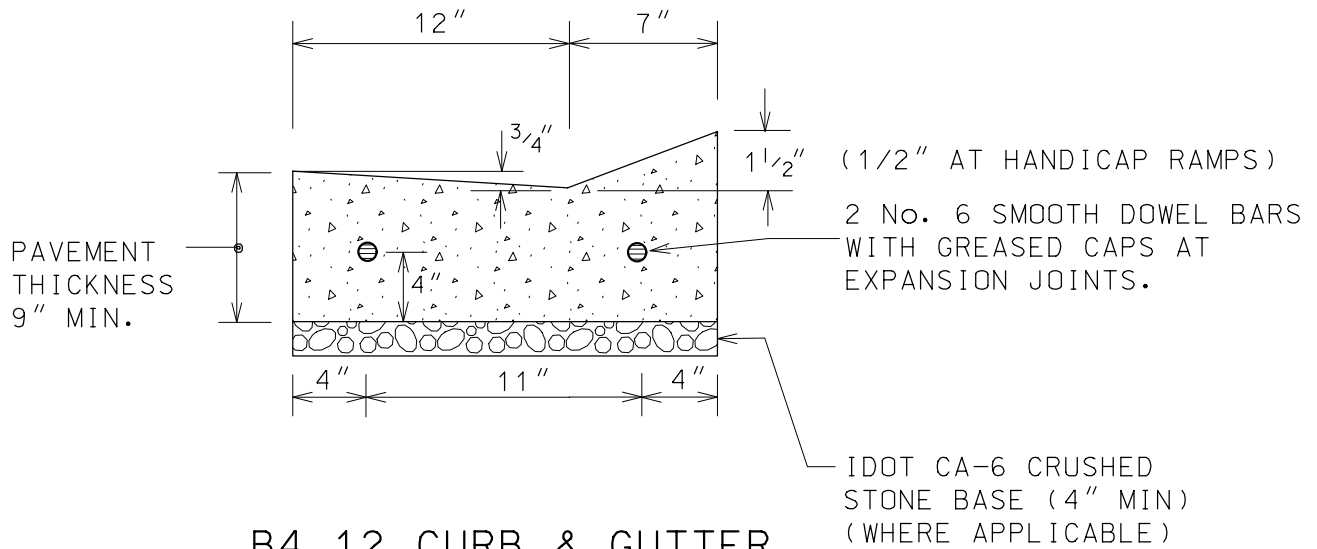

## B4.12 CURB & GUTTER

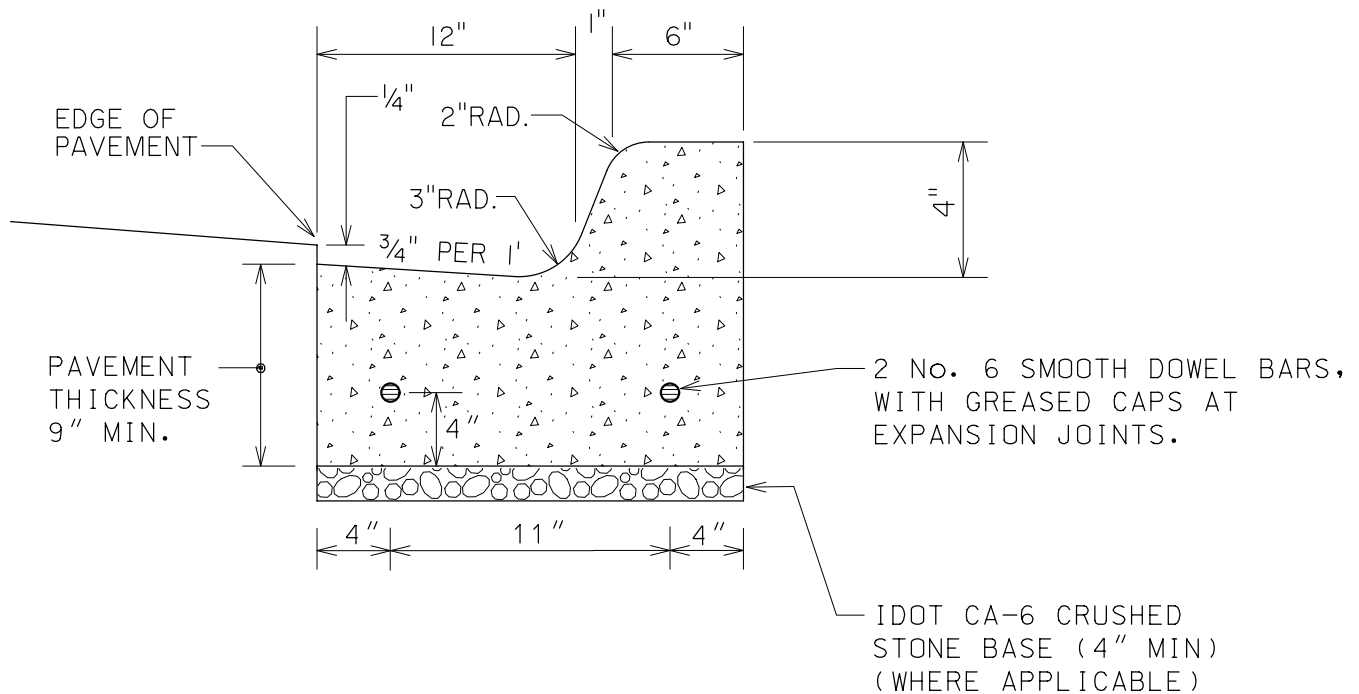

### NOTES:

1. CONTRACTION JOINTS SHALL BE PLACED AT 15' INTERVALS, AND SHALL BE GROOVED WITH AN EDGING TOOL. SEE ARTICLE 420.10 OF IDOT STANDARD SPECIFICATIONS.
2. EXPANSION JOINTS SHALL BE PLACED AT 60' (MAX) INTERVALS, AT ALL P.C.'S AND P.T.'S, CURB RETURNS, AND AT THE END OF EACH POUR
3. P.C.C. SHALL CONSIST OF IDOT CLASS SI (6.1 BAG MIX) CONCRETE, WITH 5% TO 8% AIR ENTRAINMENT, AND A MINIMUM COMPRESSIVE STRENGTH OF 3,500 PSI AT 14 DAYS. (NO FLY ASH ALLOWED)

FOR RESIDENTIAL STREETS ONLY

DATE: 10-22-10  
NOT TO SCALE

B4.12 COMB. CONCRETE CURB AND GUTTER (SPECIAL)  
B4.12 P.C.C. INTEGRAL CURB AND GUTTER (SPECIAL)