

NOTES:

1. CURB INLET CASTING SHALL BE FASTENED TEMPORARILY TO FRAME CASTING WITH 2 CAP SCREWS, DURING CONSTRUCTION
2. CAP SCREWS MUST BE REMOVED AFTER CURB HAS HARDENED.

PROFILE VIEW

NOTE:

COST OF ADDITIONAL GUTTER TO MATCH DETAIL INCIDENTAL

TOP OF CURB TO TRANSITION FROM 6" HIGH TO 3" HIGH

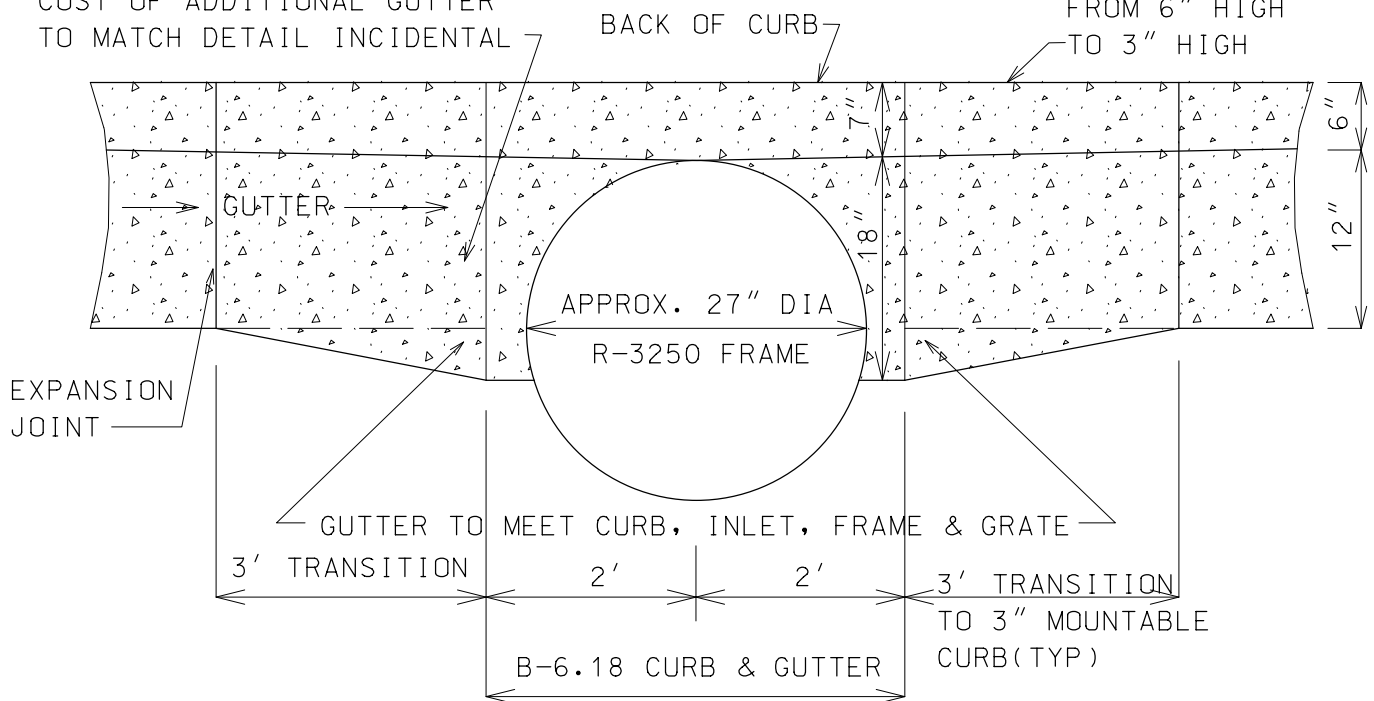

NOTES:

1. CURB CONTRACTOR TO VERIFY POSITION AND ELEVATION OF FRAME AND GRATE PRIOR TO POUR. IF NOT CORRECT, FIVE (5) FOOT TRANSITION AREA TO BE LEFT UNPOURED UNTIL SITUATION IS CORRECTED BY CONTRACTOR.

NOT TO SCALE

PLAN VIEW

**B-6.18
CURB AND
GUTTER
FOR R-3250
CURB INLET**

DATE: 3-31-09