

MOUNTABLE CONCRETE CURB & GUTTER

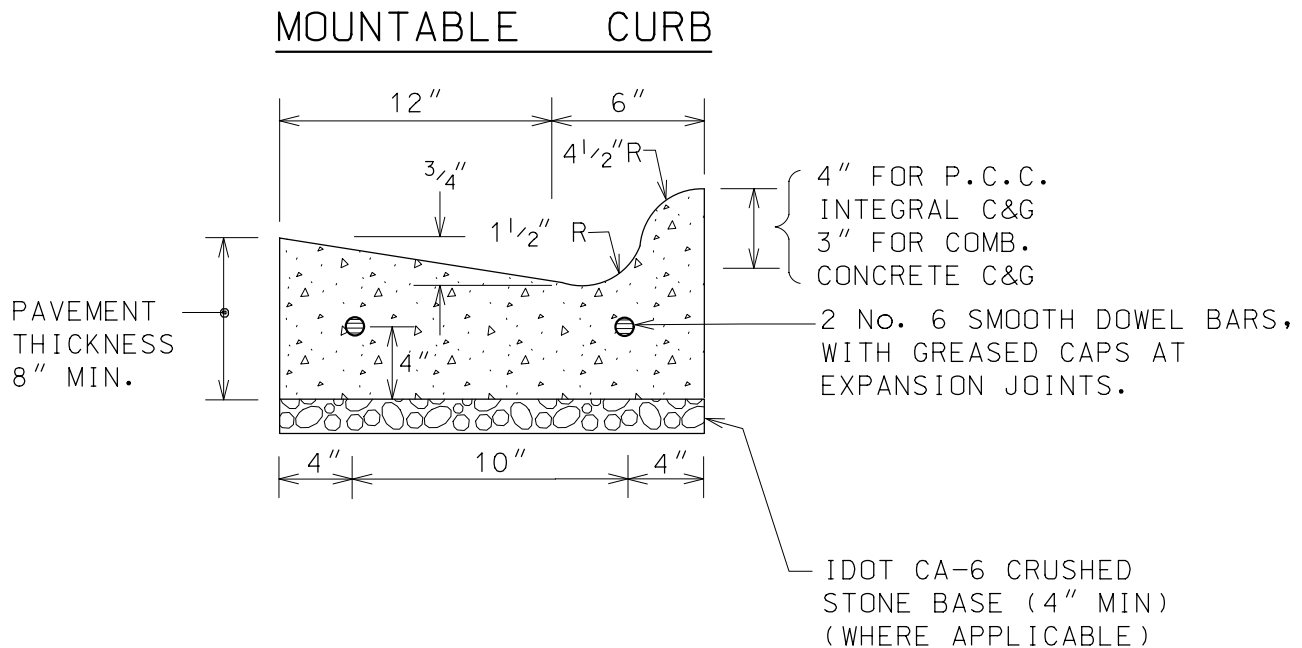

NOTES:

- 1.) 1/2" THICK PREFORMED EXPANSION JOINTS SHALL BE INSTALLED AT 50 FOOT INTERVALS. PROVIDE 2-3/4" STEEL DOWEL BARS AT EXPANSION JOINTS.
- 2.) EXPANSION JOINTS SHALL BE INSTALLED ON EACH SIDE, A DISTANCE OF 2 FEET FROM A STRUCTURE THAT FALLS WITHIN THE CURB AND GUTTER.
- 3.) CONSTRUCTION JOINTS SHALL BE SAWED TO A MINIMUM DEPTH OF 2 INCHES AND PLACED AT 10 FOOT INTERVALS. SAW CUTS SHALL BE SAWED NO SOONER THAN 6 HOURS AND NO LATER THAN 24 HOURS AFTER PLACEMENT OF CONCRETE.
- 4.) CURBS SHALL BE CONSTRUCTED IN ACCORDANCE WITH THE "STANDARD SPECIFICATIONS FOR ROAD AND BRIDGE CONSTRUCTION" (IDOT). MOST RECENT EDITION UNLESS NOTED OR DEPICTED HEREIN.
- 5.) A PROTECTIVE COAT SHALL BE APPLIED IN ACCORDANCE WITH THE STANDARD SPECIFICATIONS.

MOUNTABLE
CURB & GUTTER

DATE: 9-30-10