

PLAN

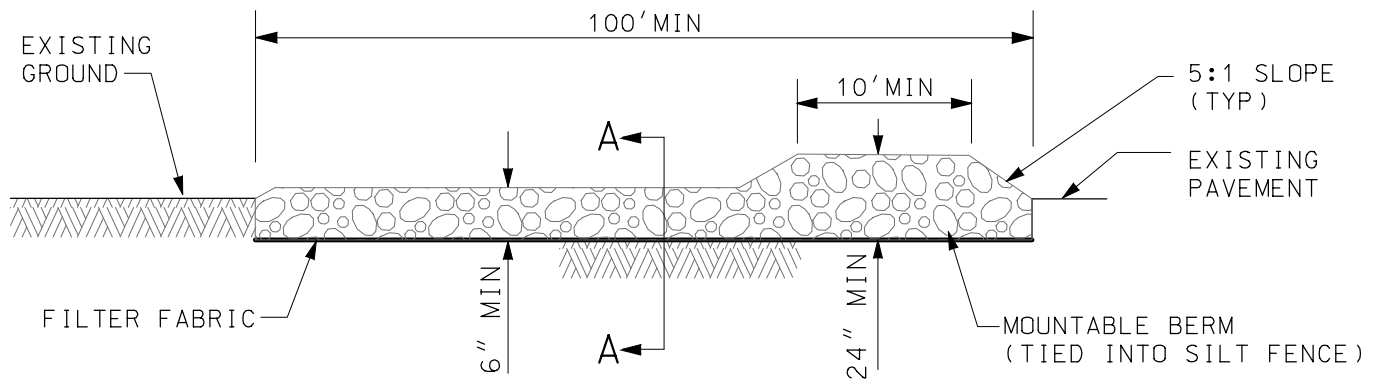

ELEVATION

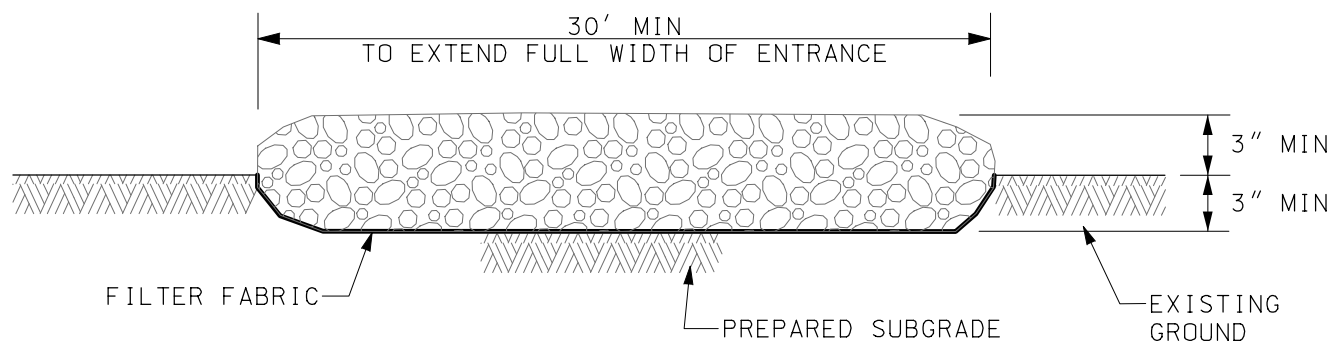

SECTION A-A

NOTES:

1. GEOTEXTILE FILTER FABRIC SHALL BE PLACED OVER THE CLEARED AREA PRIOR TO PLACING COARSE AGGREGATE
2. COARSE AGGREGATE (OR CRUSHED CONCRETE) SHALL MEET IDOT GRADATION FOR CA-1 CRUSHED AGGREGATE.
3. STABILIZED CONSTRUCTION ENTRANCE SHALL BE INSTALLED, PRIOR TO ONSET OF CONSTRUCTION OPERATIONS AND SHALL BE MAINTAINED THROUGHOUT THE PROJECT.
4. CONSTRUCTION ENTRANCE SHALL BE REMOVED UPON COMPLETION OF CONSTRUCTION AND ONLY WHEN DIRECTED BY THE CITY.

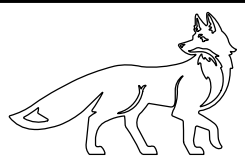

**CITY OF ST. CHARLES**  
 ILLINOIS • SINCE 1834  
*Pride of the Fox*

**STABILIZED CONSTRUCTION ENTRANCE**

DATE: 5-12-2021

NOT TO SCALE

REVISED:

DRAWING NO. F-02