

DEPRESSED CURB

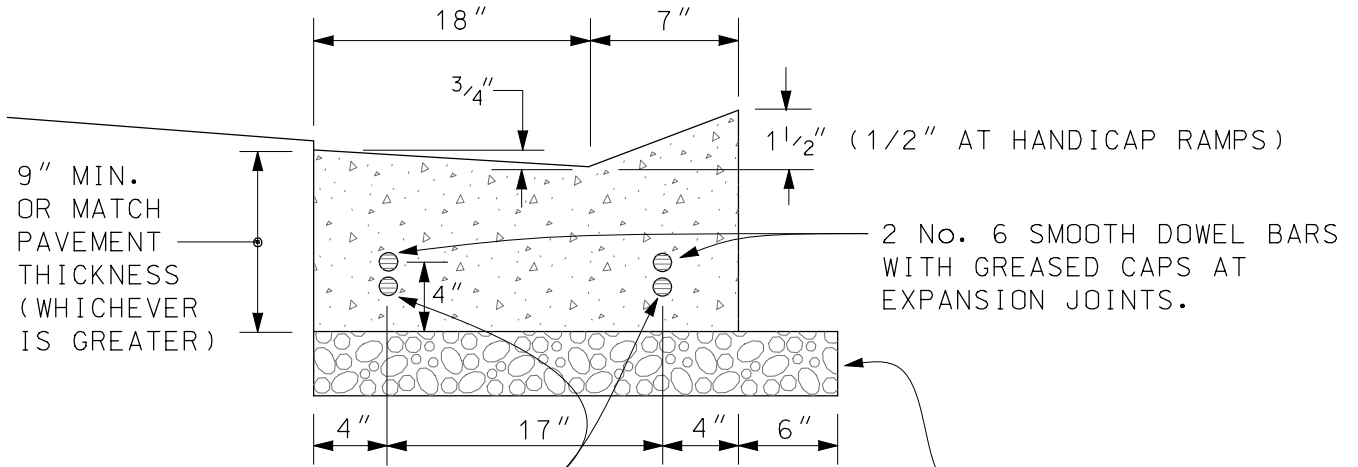

INSTALL 2 CONTINUOUS BARS
TIED TO EXISTING CURB AND GUTTER.
#4 BARS IN RESIDENTIAL,
#6 BARS IN COMMERCIAL/INDUSTRIAL

IDOT CA-6 CRUSHED
STONE BASE, 4" MIN
(WHERE APPLICABLE)

B6.18 CURB & GUTTER

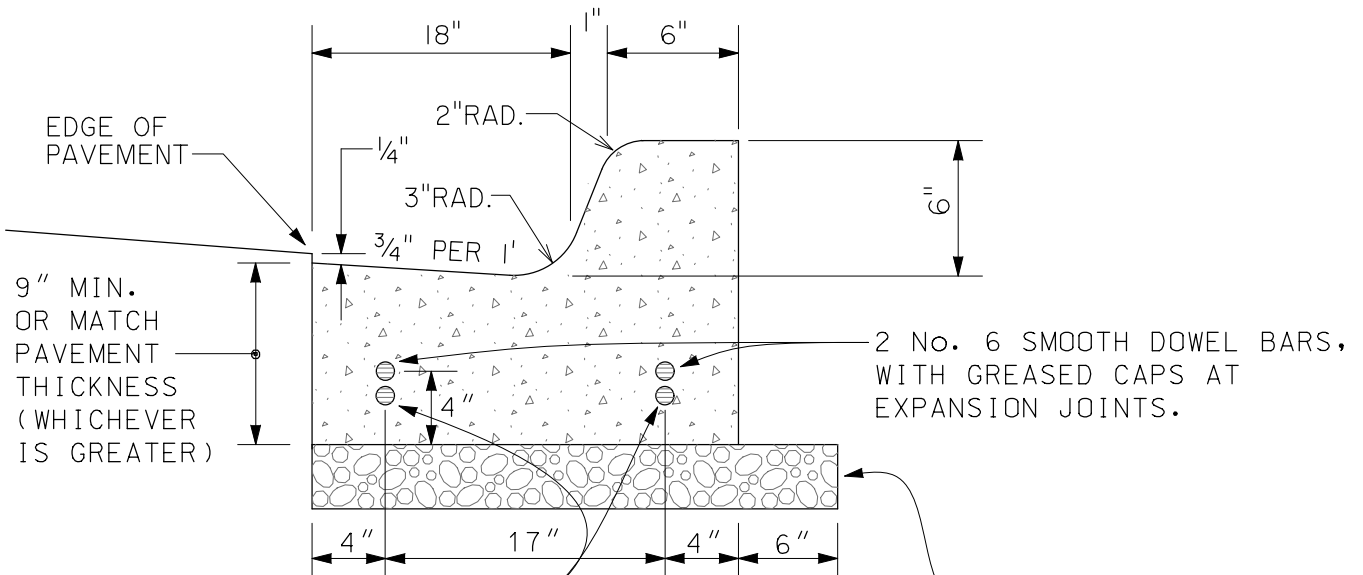

INSTALL 2 CONTINUOUS BARS
TIED TO EXISTING CURB AND GUTTER.
#4 BARS IN RESIDENTIAL,
#6 BARS IN COMMERCIAL/INDUSTRIAL

IDOT CA-6 CRUSHED
STONE BASE, 4" MIN
(WHERE APPLICABLE)

NOTES:

1. CONTRACTION JOINTS SHALL BE PLACED AT 15' INTERVALS, AND SHALL BE FORMED BY SAW CUTTING TO A DEPTH OF AT LEAST TWO INCHES.
2. EXPANSION JOINTS SHALL BE PLACED AT 60' (MAX) INTERVALS, AT ALL POINTS OF CURVATURE, AND AT THE END OF EACH POUR.

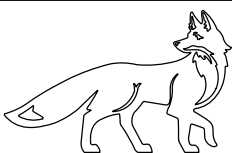

CITY OF ST. CHARLES
ILLINOIS • SINCE 1834
Pride of the Fox

TYPE B6.18 COMBINATION CONCRETE CURB & GUTTER

DATE: 9-10-2021

NOT TO SCALE

REVISED:

DRAWING NO. E-03