

ALL PAVEMENT PATCHES SHALL BE THE GREATER OF THE EXISTING CROSS SECTION OR THE FOLLOWING

A. FLEXIBLE PAVEMENT

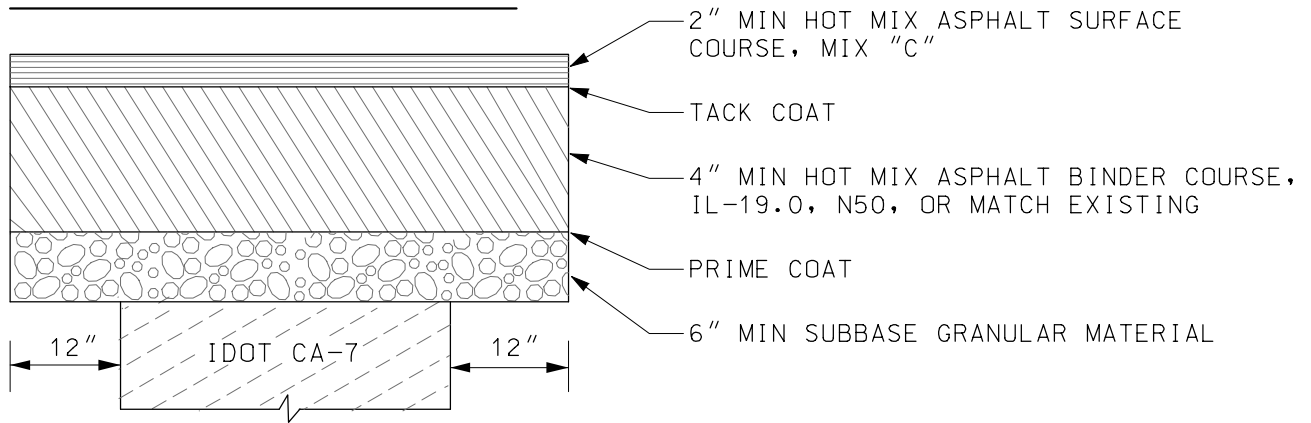

B. RIGID PAVEMENT

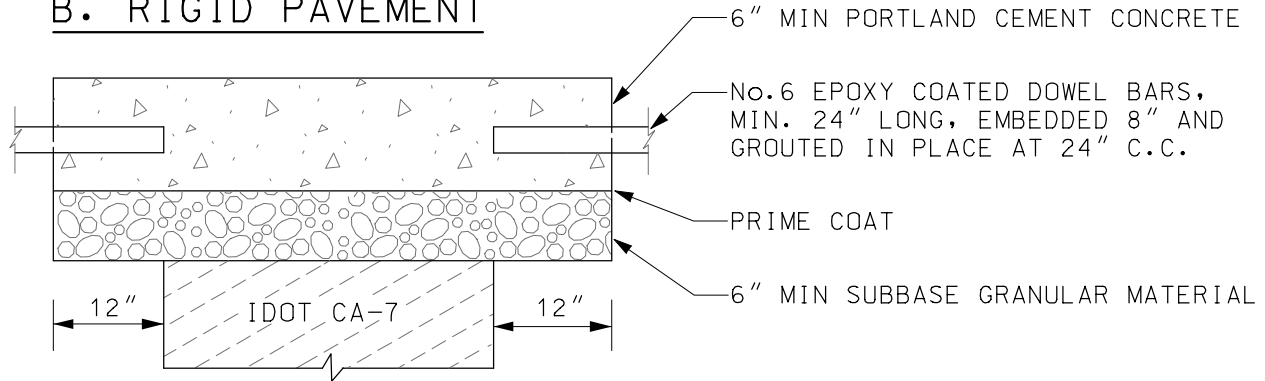

C. COMPOSITE PAVEMENT

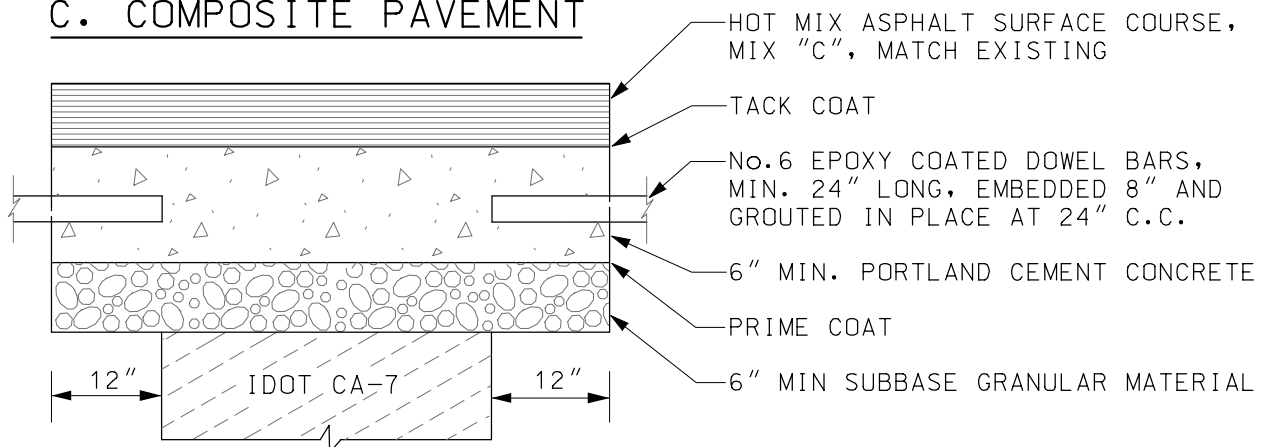

NOTES:

1. ALL PAVEMENT PATCHES SHALL BE SAWCUT FULL-DEPTH A MINIMUM OF ONE FOOT BEYOND THE LIMITS OF THE FAILED PAVEMENT IN ALL DIRECTIONS.
2. HOT MIX ASPHALT SHALL CONFORM TO IDOT HMA MIX SELECTION TABLE.

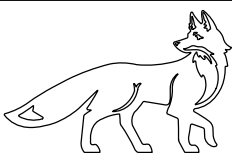

CITY OF ST. CHARLES
 ILLINOIS • SINCE 1834
Pride of the Fox

PAVEMENT PATCH

DATE: 5-12-2021

NOT TO SCALE

REVISED:

DRAWING NO. E-07