 <p>CITY OF ST. CHARLES ILLINOIS • 1834</p>	AGENDA ITEM EXECUTIVE SUMMARY		Agenda Item number: 5.D
	Title:	Recommendation to Approve a Resolution Awarding Change Order No. 2 for Repainting and Repairs to the Well # 8 Reservoirs	
	Presenter:	Tim Wilson	
Meeting: Government Services Committee		Date: May 22, 2023	
Proposed Cost: \$ 89,700		Budgeted Amount: \$94,000	Not Budgeted: <input type="checkbox"/>
TIF District: None			
Executive Summary (if not budgeted, please explain):			
<p>The Well # 8 reservoirs are two 1,000,000-gallon storage tanks that were originally constructed in the 1960's. The exterior paint on the water tank was repaired during the 1980's, and the current coating has reached the end of its life. Repainting is important to protect the steel from rust and extend the life of the tank's structure. The planned scope of work to the water tanks includes complete exterior and wet interior sandblast cleaning and repainting of the tower. The blasting and repainting of the water tanks will require containment. During the repainting, a tent-like cover will be draped around the tank to protect the surrounding area as sanding and painting is completed. Other work includes foundation maintenance, roof hatches, interior steel repairs, tank vent replacement, upgraded safety requirements mandated by OSHA and roof repairs. The bid opening was conducted on May 2, 2022 and city awarded the contract to Seven Brothers project for \$1,028,200.</p> <p>While conducting the sandblasting and inspection inside the tank it was discover additional steel needed to be replaced. Some of the internal structural framing members were greatly deteriorated and they are needed to help to support the roof when snow loads are applied. These circumferential roof stiffeners run the entire diameter of the tank. The horizontal side of this steel has deteriorated almost completely and is no longer providing the stiffness and support as originally intended. In addition, the vertical side has also experienced some deterioration, further reducing the structural section of this member. Dixon Engineering structural team has reviewed the condition and is recommending the full replacement of this steel support.</p> <p>City staff is recommending a contract change order in the amount of \$89,700 to cover the cost of this steel repair. This change order will not require a budget adjustment; knowing we had a similar issue on the other tank on this site last fall, the Public works team increased this year's budget to cover the expected change.</p>			
Attachments (please list):			
*Photos and Change order			
Recommendation/Suggested Action (briefly explain):			
Recommendation to approve a Resolution awarding Change Order No. 2 for Repainting and Repairs to the Well # 8 Reservoirs to Seven Brothers in the amount of \$89,700.			

Section 00 63 57 - Change Order Price Request Form
City of St. Charles, Illinois
(2) 1,000,000 Gallon Reservoir (East & West)
Exterior Overcoat, Wet Interior Repaint, and Miscellaneous Repairs

May 4, 2023
Bulletin No. 2

Provide prices for the following items on the West Reservoir:

- 1) Remove the corroded circular roof stiffener and grind flush with the roof plate. Weld an angle to replace the removed angle. Reweld the existing radial stiffener connection points to the new circular angle using ¼ in. full fillet seal welds. The Contractor is to disconnect no more than two adjacent radial stiffeners at a time. Temporary support of the roof is the responsibility of the contractor. See the attached Drawing 10 for details.

Eighty Nine Thousand Seven Hundred Dollars

\$ 89,700.00

Lisa Mitchell

Contractor Signature

May 5th, 2023

Date

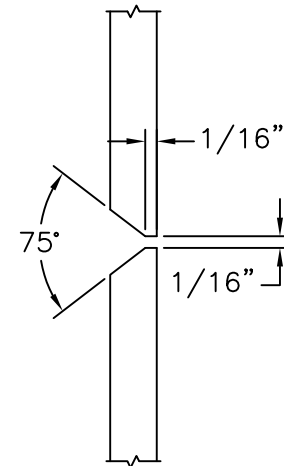
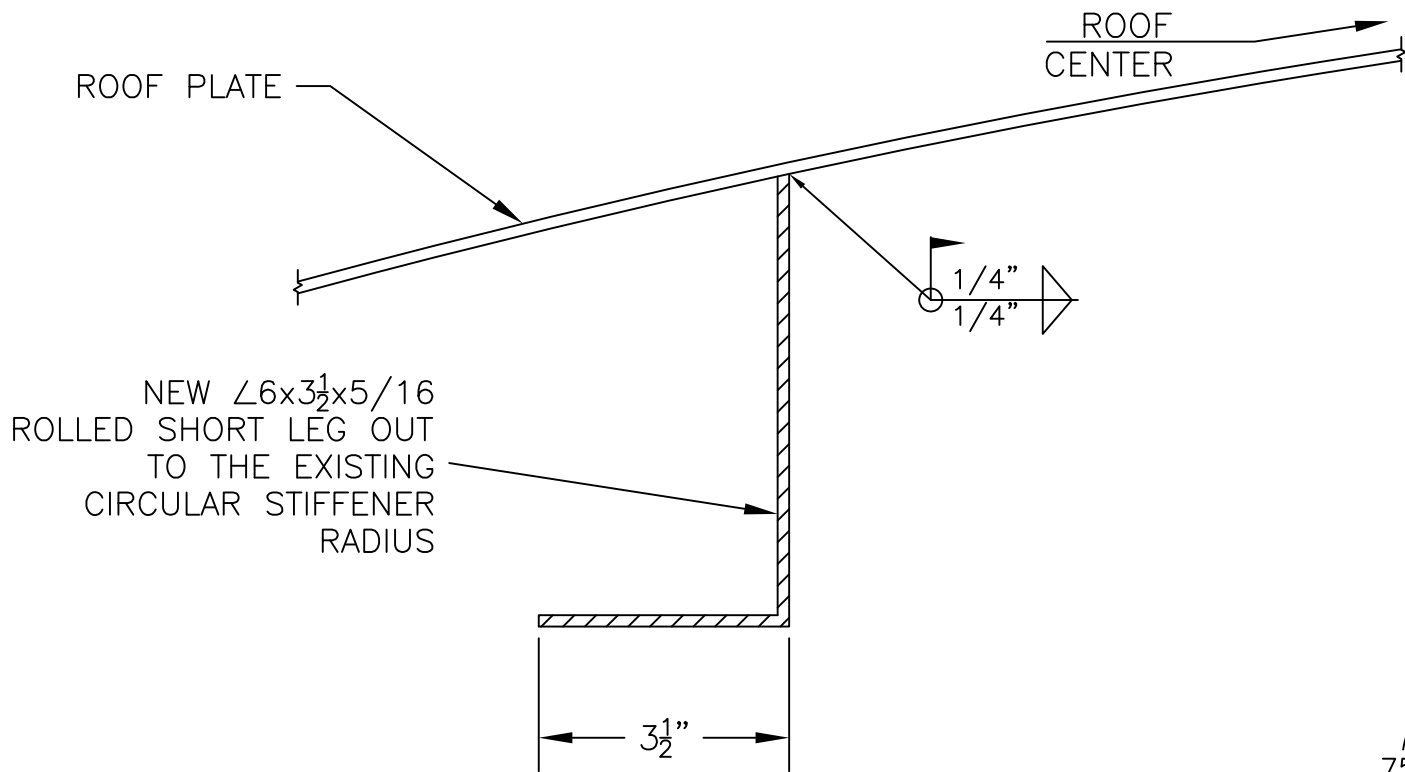

WELD DETAIL

AT ADJOINING ENDS FOR THE NEW ANGLE

Note: Drawing not to scale.



St. Charles, IL West Res.

Roof Stiffener Replacement

Drawn By: TMF Date: 05/04/23

Checked By: JVR DWG: 10

