



**AGENDA ITEM EXECUTIVE SUMMARY**

Agenda Item number: 3b

Title:	Historic Preservation Commission recommendation to approve a Façade Improvement Grant Agreement for 11 S. 2 <sup>nd</sup> Ave.
Presenter:	Ellen Johnson

Meeting: Planning & Development Committee

Date: September 11, 2017

Proposed Cost: \$18,572.60

Budgeted Amount: \$40,000

Not Budgeted:

**Executive Summary** *(if not budgeted please explain):*

Hossein Jamali, owner of 11 S. 2<sup>nd</sup> Ave., has requested a Façade Improvement Grant to help fund replacement of 23 windows on the building. Existing windows are steel and window replacements will be custom-made steel replicas.

The Façade Improvement Grant program provides assistance to property owners and commercial tenants to rehabilitate and restore the exterior of buildings in the downtown. Grant funding is available for buildings located in Special Service Area 1B (Downtown Revitalization) or in a Historic District or designated Historic Landmark site. Applications are first reviewed by the Historic Preservation Commission for appropriateness of design. The grants are provided as a reimbursement for up to 50% of the funds invested into an exterior rehabilitation project involving new improvements or maintenance using historic preservation practices, and up to 25% for maintenance work. Up to \$10,000 is available for a 30 ft. length of building façade. There is a limit of \$20,000 of grant funds per property in any 5 year period. The program budget for FY 17-18 is \$40,000.

The Historic Preservation Commission reviewed the grant and recommended approval on 9/6/17.

The cost of the eligible improvements is estimated at \$45,178 and the grant would cover up to \$18,572.60, based on the length of the building façade.

**Attachments** *(please list):*

Location Map, Historic Commission Resolution, Façade Improvement Grant Application, Grant Agreement

**Recommendation/Suggested Action** *(briefly explain):*

Historic Preservation Commission recommendation to approve a Façade Improvement Grant Agreement for 11 S. 2<sup>nd</sup> Ave.



City of St. Charles, Illinois

Two East Main Street St. Charles, IL 60174-1984  
Phone: 630-377-4400 Fax: 630-377-4440 - www.stcharlesil.gov

11 S 2nd Ave.

RAYMOND ROGINA

Mayor

MARK KOENEN

City Administrator

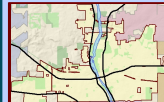

Data Source:  
City of St. Charles, Illinois  
Kane County, Illinois  
DuPage County, Illinois  
Projection: Transverse Mercator  
Coordinate System: Illinois State Plane East  
North American Datum 1983  
Printed on: September 7, 2017 10:16 AM



0 42 83 Feet

This work was created for planning purposes only and is provided as is, without warranty of any kind, either expressed or implied. The information represented may contain proprietary and confidential property of the City of St. Charles, Illinois. Under United States Copyright protection laws you may not use, reproduce, or distribute any part of this document without prior written permission. To obtain written permission please contact the City of St. Charles at Two East Main Street, St. Charles, IL 60174  
Powered by Precision GIS



**City of St. Charles, Illinois**

**Historic Preservation Commission Resolution No. 8-2017**

**A Resolution Recommending Approval of  
A Façade Improvement Grant Application  
(11 S. 2<sup>nd</sup> Ave.)**

WHEREAS, it is the responsibility of the St. Charles Historic Preservation Commission to review applications for the Façade Improvement Grant Program; and

WHEREAS, the Historic Preservation Commission has reviewed the Façade Improvement Grant Application for 11 S. 2<sup>nd</sup> Ave. and has found said application to be architecturally appropriate and in conformance with the Downtown Design Guidelines and the Historic Preservation Ordinance, Chapter 17.32 of the Zoning Ordinance; and

WHEREAS, the Historic Preservation Commission finds approval of said Façade Improvement Grant Application to be in the best interest of the City of St. Charles.

NOW THEREFORE, be it resolved by the St. Charles Historic Preservation Commission to recommend to the City Council approval of the Façade Improvement Application for 11 S. 2<sup>nd</sup> Ave.

Roll Call Vote:

Ayes: Norris, Gibson, Smunt, Pretz, Kessler, Krahenbuhl

Nays: None

Abstain: None

Absent: Malay

Motion Carried.

**PASSED**, this 6<sup>th</sup> day of September, 2017.

---

Chairman

# FAÇADE IMPROVEMENT GRANT APPLICATION



ST. CHARLES  
SINCE 1834

COMMUNITY & ECONOMIC DEVELOPMENT DEPT. /PLANNING DIVISION

CITY OF ST. CHARLES

## Grant Type (select one):

- Commercial       Residential

## Property Information:

Building or establishment for which the reimbursement grant is requested:

Address:

115 2nd Ave

Property Identification Number:

09-27-389-008

Applicant Name:

Hossein Jamali



## Project Description:

window replacement for building

Total Cost Estimate:

\$ 45,178

## Submittal Checklist:

- \$50 Application Fee
- Detailed Scope of Work:** Must identify all improvements, construction methods, building materials to be used. Costs must be broken down and itemized by task. In general, this scope of work should be prepared by the contractor(s) who will be completing the project.
- Documentation on Existing Conditions:** Reports or photographs to demonstrate need for improvements.
- W-9 Form:** Filled out and signed by the grant applicant, with a Federal Tax ID Number (or a Social Security Number for an individual)

**Applicant Contact Information:**

Phone Number: 630-921-8222

Email Address: h.jamali@meson.sabita.com

**Statement of Understanding:**

- I agree to comply with the guidelines and procedures of the Façade Improvement Grant Program. I have read and understand the "Terms and Conditions".
- I understand that I must submit detailed cost documentation, copies of bids, contracts, invoices, receipts, and contractor's final waivers of lien upon completion of the approved improvements.
- I understand that work done before a Façade Improvement Agreement is approved by the City Council is not eligible for a grant.
- I understand the Façade Improvement reimbursement grants are subject to taxation and that the City is required to report the amount and recipient of said grants to the IRS

Signature:  Date: 8-22-17  
Applicant

**Owner Authorization (if applicable):**

If the applicant is other than the owner, you must have the owner complete the following certificate:

I certify that I am the owner of the property at 115 2nd Ave, and that I authorize the applicant to apply for a reimbursement grant under the St. Charles Façade Improvement Program and undertake the approved improvements.

Signature: \_\_\_\_\_ Date: \_\_\_\_\_  
Owner



11 S. 2nd Ave.  
West Side (alley side)









Portion of south side (Walnut Ave.)





Portion of south side











561 MURFREESBORO PIKE • NASHVILLE, TN • 37210 • TELEPHONE: 615-751-8116 • 800-826-8719 • WINDOWCITYINC.COM

August 15, 2017

Paul Saha  
P.S. Construction  
St. Charles Historic  
St. Charles, IL

**Subject: Proposal for the Replacement of Windows at St. Charles Historic**

Paul,

Thank you for the opportunity to present this proposal.

If I can provide additional information not included in this proposal, please do not hesitate to contact me or my appointed contact person, Alex Lagos.

You can be sure that if selected, we will use all the resources available to ensure the successful completion of the project.

Sincerely,

Michael P. Mastroberti  
President  
Office: (973) 473-4343 Ext. 111  
Email: [mikem@windowcityinc.com](mailto:mikem@windowcityinc.com)

Alex Lagos  
Architectural Sales | Project Manager  
Office: (800) 826-8719 ext. 128  
Cell: (615) 913-2346  
Email: [AlexL@windowcityinc.com](mailto:AlexL@windowcityinc.com)



**St. Charles Historic  
P.S. Construction  
St. Charles, IL**

**Window Replacement Proposal**

**WINDOW CITY**  
THE TOTAL WINDOW SOLUTION™

561 MURFREESBORO PIKE • NASHVILLE, TN • 37210 • TELEPHONE: 615-751-8116 • 800-826-8719





561 MURFREESBORO PIKE • NASHVILLE, TN • 37210 • TELEPHONE: 615-751-8116 • 800-826-8719 • WINDOWCITYINC.COM

August 15, 2017

Paul Saha  
P.S. Construction  
St. Charles Historic  
St. Charles, IL

**Re: St. Charles Historic – Window Replacement**

Paul,

Please find Window City, Inc.'s (Window City) proposal for the above referenced project. Our proposal is based on the following information: pictures / phone, email correspondence.

Window City proposes to furnish and install only the material covered within this proposal.

<b>Base Bid Amount:</b>	<b>\$45,178</b>
<b>Option Add #1: (Bottom Awnings)</b>	<b>\$ 9,872</b>

**General Scope of Work:**

Furnish labor, material, equipment and services necessary for the completion of the project.

- Coordination of installation and schedule with Owner
- All field measuring, ordering and fabrication by Window City
- Schedule, accept and off-load all deliveries
- Removal of existing windows, glass and sash by Window City
- All windows and doors shall be installed square and level
- All debris shall be discarded from the job site
- All exterior and interior perimeter caulking
- Removal and reinstallation of all window treatments shall be by Others
- Professional, uniformed in-house installation crew (No Subcontractors)

**Base Bid Materials**

**Windows:**

- Universal 700 Series, Aluminum Steel-Replica Windows, Fixed
- Clear Double Insulated Glass w/Low-E, Argon Gas Fill
- Finish: Baked Acrylic, Dark Bronze (AAMA 2603)
  - Standard colors include Black, Dark Bronze, Hartford Green, White, Ivory
- Grids: Exterior, GBG
- Factory Muller

## Option Add/Deduct Materials

### **Option Add #1:**

- Universal 700 Series, Aluminum Steel-Replica Windows, Fixed w/Bottom Awning (Project Out)
- Clear Double Insulated Glass w/Low-E, Argon Gas Fill
- Finish: Baked Acrylic, Dark Bronze (AAMA 2603)
  - Standard colors include Black, Dark Bronze, Hartford Green, White, Ivory
- Grids: Exterior, Grids Between Glass
- Factory Muller

## Base Bid Quantities

**Windows:** (23) – Type A: (44 x 62)

## Exclusions & Qualifications

- This proposal is valid for the materials contained within it only. All changes must be conveyed to Window City.
- All labor shall be Non Union open shop
- **Note: Our proposal is NOT based on providing a lead safe window installation, using lead safe installation practices as per EPA regulation 40 CFR 745 that went into effect on 4/22/10.**
- Window City to have free and easy access to both the interior and exterior of all window openings to install the windows.
- **Window City excludes the following:** Air and water tests by independent testing company, independent mock ups, concrete repair, lintel repair, preparation of openings, final cleaning, bonds, PE stamp, interior sills, trim, stools, moldings, master keying, the removal and replacement of window treatments and AC units, the protection of installed materials and interior finish work (trims, finish painting and spackling).
- Window City reserves the right to void this proposal after (30) days.
- Owner/GC to provide adequate electrical supply (110v) and elevator service to complete the scope of work.
- If necessary, Owner/GC to provide all required sidewalk protection, bridging and/or building netting. Owner/GC to provide all required building permits, licenses, and state and local code requirements. Window City accepts no responsibility for the aforementioned or any other additional local or municipal requirements.
- Window City accepts no responsibility for the aforementioned or any other additional local or municipal requirements.
- Final pricing to reflect actual quantities installed.
- Window City implements a 3% service fee to all credit card payments.

## General Terms

The prices quoted are with the understanding that Window City is to furnish all labor, materials, and equipment necessary to perform all work in a workman-like manner according to standard practices. Unless otherwise specified, prices quoted in this proposal are based on the award of the entire contract and doing the work Monday through Friday 7:00 A.M. to 5:00 P.M. Absent specific contract provisions for work being conducted during night time, weekends, or holidays, an additional \$60.00 per man-hour charge will be added to the quoted price for such work, inclusive of mobilization and driving time. The property owner or their representative is responsible for identifying and disposal of any and all hazardous materials at their location (i.e. asbestos, mold, PCB's etc.) that could cause harm to our employees, the building's occupants or the general public.



**DISCLAIMER**

The proposal set forth herein was prepared by Window City utilizing architectural drawings and/or a preliminary field assessment, and Window City’s experience in the industry performing work on similar projects.

Although Window City may employ engineers and architects, the Proposal is not and should not be considered an “engineer’s report” or an “architect’s report.” The Owner is encouraged to obtain the services of a licensed engineer or a licensed architect to verify the condition of the Owner’s Property and the recommendations contained in this Proposal. Window City expressly disclaims any liability whatsoever arising from or related to the Company’s analysis of existing conditions of the Owner’s Property and/or the Company’s recommendations for repair/remediation based upon such analysis. Further, while the Company may have performed limited tests on materials that are a part of the Owner’s Property, Owner is hereby advised that additional detailed testing that may not have been used by the Company could indicate or may warrant different recommendations.

All contracts are subject to approval of final terms and conditions.

Respectfully yours,

Alex Lagos  
Architectural Sales | Project Manager  
Office: (615) 826-8719 ext. 128  
Cell: (615) 913-2346  
Email: [AlexL@windowcityinc.com](mailto:AlexL@windowcityinc.com)

**Window City is a Proud Member of**





561 MURFREESBORO PIKE • NASHVILLE, TN • 37210 • TELEPHONE: 615-751-8116 • 800-826-8719 • WINDOWCITYINC.COM

## Experience & Qualifications

- ❖ Which elements of the window replacement will be managed by a third-party other than Window City?  
Each phase of project development will be handled directly by Window City. Window City uses our own in-house, uniformed installation crews with on-site project foreman and on-site field superintendent. No subcontractors will be used. All stages of the project, including coordination with the window manufacturer, will be governed by Window City's Operations Protocol as detailed in our company's Operations Manual.
- ❖ Describe Window City's experience with the design of exterior window systems:  
Window City principals have consulted with leading manufacturers on window system product development. The majority of our projects call for us to work hand-in-hand with an owner's architect or engineer. While our project managers routinely advise our customers on potential design options, our company's strength lies in executing the specific plan as put forth in cooperation with the architect or project engineer.
- ❖ Detail the number of distinct projects that Window City has completed:  
Window City has provided turnkey window replacement expertise to more than 400 medium (\$100,000--\$499,000) and large-scale (\$500,000+) projects since 1986. With more than 1 million windows and doors installed, Window City is committed to being "The Total Window Solution™" for our customers. *(for pictures, please see Window City's website)*
- ❖ Detail the general types of projects that Window City installs:
  - High-Rise and Mid-Rise Window Replacement (condo/co-op/office)
  - Garden Apartment and Multi-Family Window Replacement
  - Mill Conversion and Building Conversion Window Replacement
  - Office and Industrial Window Replacement
  - School and Church Window Replacement
  - Hospitality and Hotel Window Replacement
  - Healthcare and Hospital Window Replacement
  - Senior and Assisted Living Window Replacement
  - Historic Restoration and Landmark Window Replacement
- ❖ Detail the types of customers you have worked with in the past:  
Building Owners, Property Managers, General Contractors, Architects, Engineers, Developers, Condo and Co-Op Boards.
- ❖ Describe implementation of window replacement construction standards and other safety measures:  
All superintendents and foremen are credentialed OSHA 30 and Lead-Safe Protocol certified. All field personnel are OSHA 10 certified and undergo quarterly training programs on the latest safety and construction methods and procedures. Our unmatched craftsmanship adheres to the most up-to-date building code guidelines and industry standards of excellence.  
Safety is a fundamental priority at Window City. To ensure safe execution of each window and door replacement project, operation managers prepare and implement a proper work plan specific to the project. The goal on every project is zero incidents and zero injuries. Window City is committed to realizing this goal wherever the company has presence. Window City's safety objective reaches every part of the company's operations and extends to customers, the public and the products supplied.  
Training is key to preventing incidents and injuries. Window City's health, safety and security training program contains processes, procedures and instruction that form the basis of the company's proactive "total safety culture." Window City employees receive extensive training on how to perform all jobs safely, properly and in compliance with industry regulations and standards.



❖ Provide customer references from customers who worked with you during the installation phase of a major project:

Dennis Siclari  
Lehigh Valley Ventures, LLC  
President  
Project: P&P Mills Loft Conversion  
Phone: (908) 507-6512

Bill Rafferty  
Schindler Elevator Corporation  
Manager, Building Services  
Project: Schindler Elevator Headquarters Window Replacement  
Phone: (973) 397-6177

Lionel Kier  
BTC Management Corp  
Executive Director  
Project: Trent Center West  
Phone: (609) 392-5222, x-103

Tony Hodum  
The Solomon Organization, LLC  
Vice-President of Construction  
Project: Candlewyck Park Apts, Fox Run Apts, Wilbur Apts, Gas Light Village  
Phone: (908) 988-1000 Ext.1040

Tim Ross  
Goldfarb Properties  
Vice-President of Construction & Special Project  
Project: 1160 5th Ave, Park Towers South, Maple Gardens  
Phone: (914) 235-3200

Nancy Morris  
Regional Manager ARM  
Freeman Webb Companies  
Project: Terrace Hills Apts.  
Phone: (615) 271-2700

Steve Kenagy  
Medical Pavilion Investors  
Manager, Building Services  
Project: Doctor's Pavillion  
Phone: ( 615 ) 417-4797

Ryan Tobin  
Rehab Builders, LLC  
VP of Construction  
Project: Mebane Mill Lofts  
Phone: (336) 722-6132

Michael McAlister  
Select Specialty Hospital  
Chief Operating Officer  
Project: Specialty Select Hospital Facility  
Phone: (615) 284-6707

- ❖ Describe your team organization:  
Window City takes our core values and team approach very seriously. Our core values flow from the company's overarching commitment to professionalism and customer focus. Within the company, this commitment to professionalism and customer focus is referred to as "The Window City Way."

Below are the core values that made Window City one of the most respected full-service window replacement companies east of the Mississippi. To read more about what these core values mean to our team members, visit our website under the COMPANY tab, CORE VALUES page. **Professionalism, Customer Focus, Consideration, Preparation Proactive, Passion and Community Minded.**

- ❖ Detail the number of exterior window systems that Window City has managed for more than one year:  
Window City's service program monitors all projects post installation. A 24 hour/7 day a week stocked service van maintenances and services all window and door related issues. After the completion of each project, all Window City customers receive close-out documents and window parts lists for future service-related issues. Our customers have come to expect the highest standard of service before, during and after the installation is complete.
- ❖ Provide location of your headquarters/main office:



**Main Office:**  
162 Highland Ave  
Clifton, NJ 07011

**Nashville Office:**  
561 Murfreesboro Pike  
Nashville, TN 37210



Safety  
Stability  
Service  
Value



# WINDOW CITY

THE TOTAL WINDOW SOLUTION™

## Fast Facts:

- Family Owned & Operated Since 1986
- Single Source Total-Package Expertise
- National Execution Platform
- Over 1 Million Windows & Doors Installed
- In-House, Uniformed, OSHA Cert'd Crews
- 15 to 15,000 Windows

## Mission Statement:

To be the most admired and highly sought after full-service company in the fenestration industry.

## Core Values:

- PROFESSIONALISM
- CUSTOMER FOCUS
- CONSIDERATE
- PREPARATION
- PROACTIVE
- PASSION
- COMMUNITY MINDED

\*\*\* Visit [windowcityinc.com](http://windowcityinc.com) to learn more about what these core values mean to our employees.

## Environmental Commitment:

Window City is a proud member of the United States Green Building Council. Window City is committed to sustainable design practices and recognizes the overall benefits not only to the environment, but also the owners and occupants of these buildings.



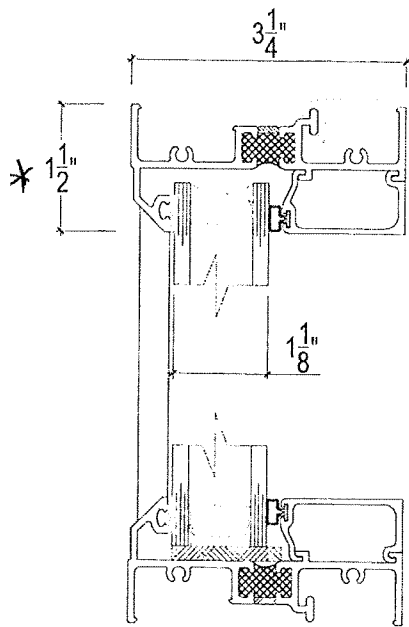

1-STEEL REPLICA HEAD  
NARROW FIXED FRAME  
SHOWN w/ OPTIONAL STRAP ANCHOR

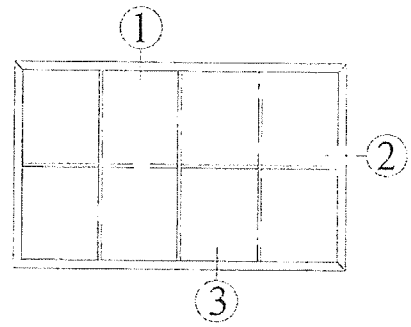

2-STEEL REPLICA HEAD  
NARROW FIXED FRAME

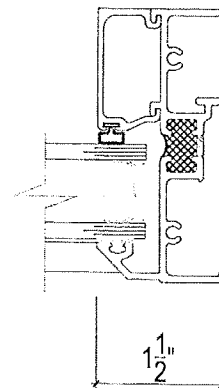

3-STEEL REPLICA HEAD  
NARROW FIXED FRAME

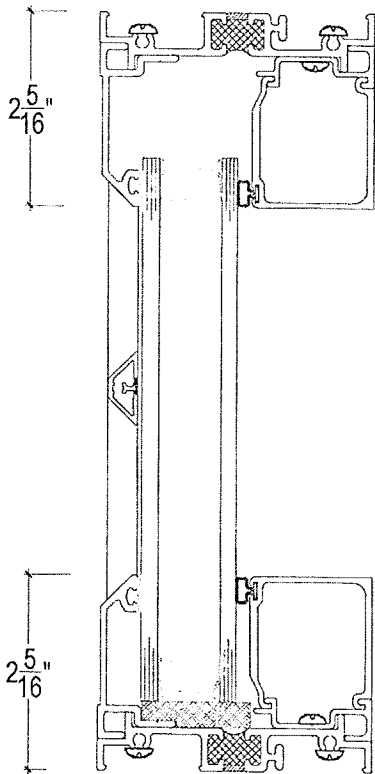

1-STEEL REPLICA HEAD  
EXTENDED FIXED FRAME

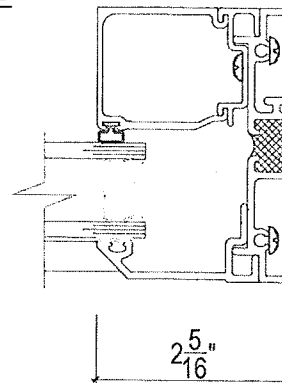

3-STEEL REPLICA HEAD  
EXTENDED FIXED FRAME

2-STEEL REPLICA HEAD  
EXTENDED FIXED FRAME

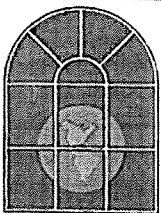

**UNIVERSAL WINDOW  
AND DOOR, LLC.**

303 Mechanic Street  
Marlborough, MA 01752  
800-633-0108 508-481-2850  
www.universalwindow.com

**UNIVERSAL 700 STEEL REPLICA  
FIXED WINDOW**

DATE:  
2-10-2011

DWG #:  
UNI-700-0001

REV:  
A

SCALE: NTS

DRAWING FOR FAMILIARIZATION  
ONLY, ACTUAL DETAIL MAY VARY



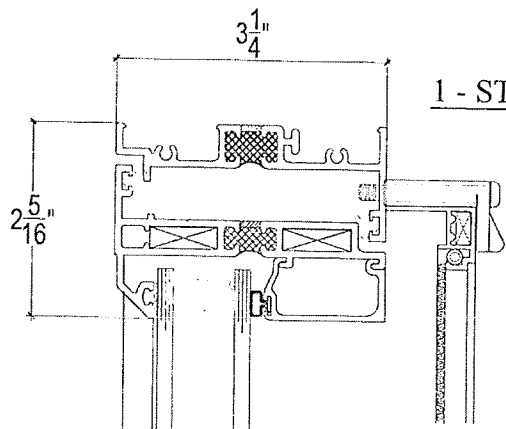

1 - STEEL REP. VENT  
@ HEAD

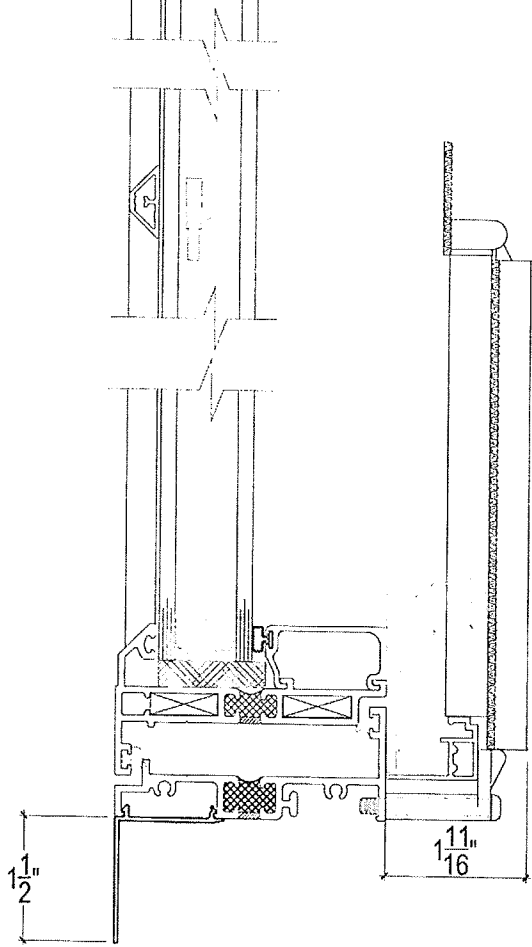
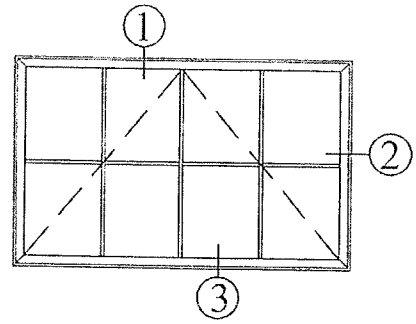

2 - STEEL REP. VENT  
@ SILL

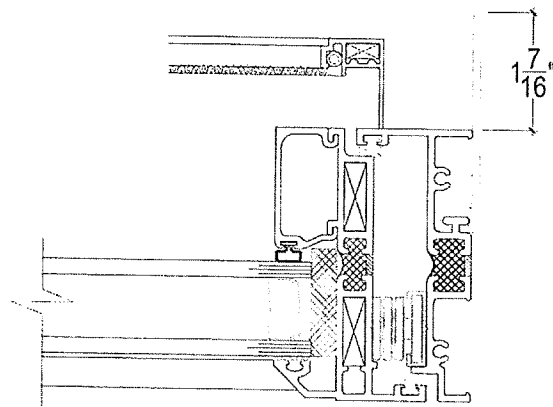

3 - STEEL REP. VENT  
@ JAMB  
JAMB SHOWN WITH  
OPTIONAL STRAP ANCHOR

DRAWING FOR FAMILIARIZATION  
ONLY, ACTUAL DETAIL MAY VARY

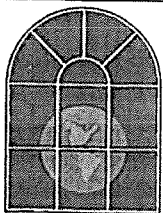

**UNIVERSAL WINDOW  
AND DOOR, LLC.**

303 Mechanic Street  
Marlborough, MA 01752  
800-633-0108 508-481-2850  
www.universalwindow.com

**UNIVERSAL 700 STEEL REPLICA  
SINGLE VENT WINDOW**

DATE:  
11-03-2015

DWG #:  
UNI-700-0002

REV:  
A

SCALE: NTS

1 - STEEL REP. FIXED

@ HEAD

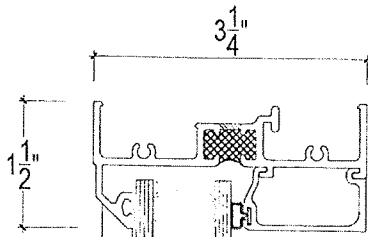

6 - STEEL REP. VENT/FXD

@ MULLION

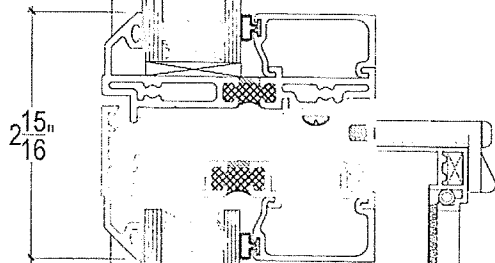

2 - STEEL REP. VENT

@ SILL

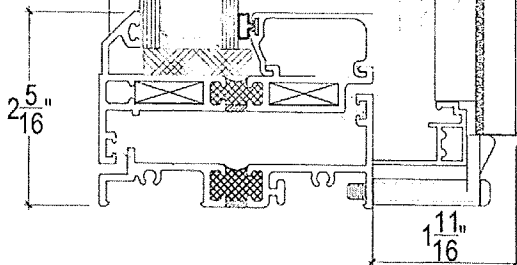

3 - STEEL REP. VENT

@ JAMB

SHOWN w/ STRAP ANCHOR

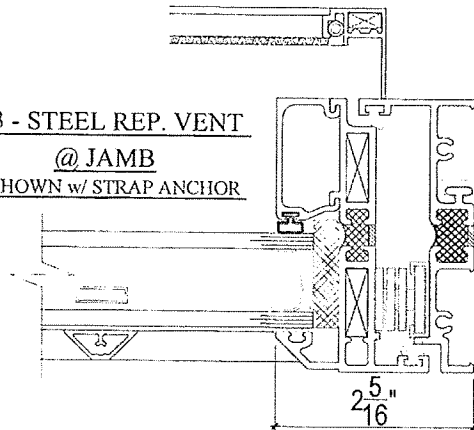

4 - STEEL REP. FIXED

STANDARD FRAME

@ JAMB

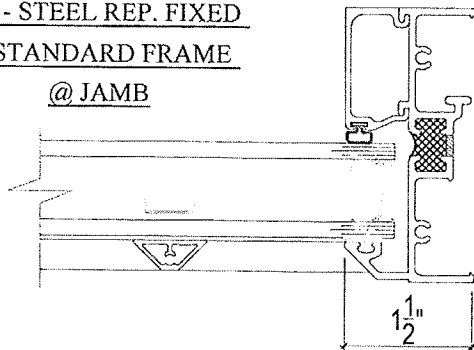

5 - STEEL REP. FIXED

EXTENDED FRAME

@ JAMB

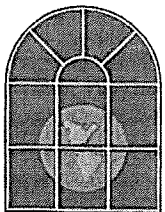
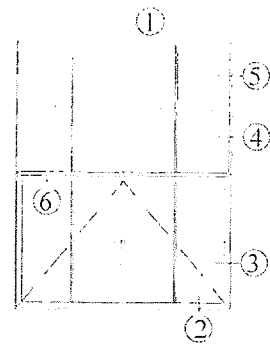
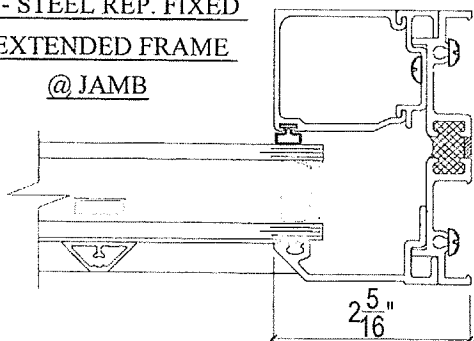

**UNIVERSAL WINDOW AND DOOR, LLC.**

303 Mechanic Street  
Marlborough, MA 01752  
800-633-0108 508-481-2850  
www.universalwindow.com

**UNIVERSAL 700 STEEL REPLICA FULL VENT OVER FIXED**

DATE: 11-03-2015

DWG #: UNI-700-0003

REV: A

SCALE: NTS

DRAWING FOR FAMILIARIZATION ONLY. ACTUAL DETAIL MAY VARY

1 - STEEL REP. FIXED  
@ HEAD

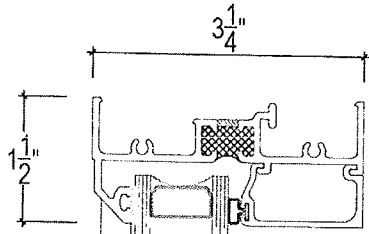

3 - STEEL REP. VENT  
@ JAMB

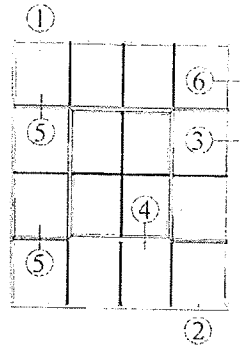
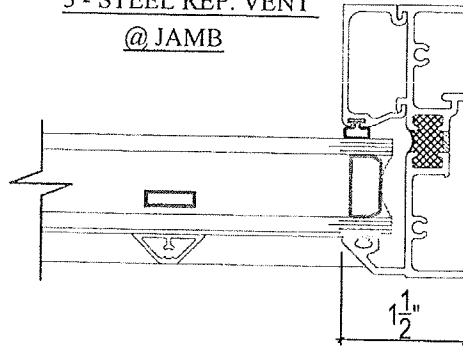

5 - STEEL REP. FXD/FXD  
@ MULLION

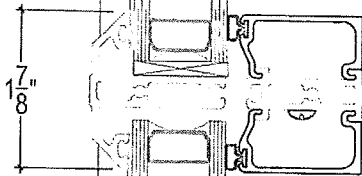

4 - STEEL REP. VENT  
@ VERTICAL MULLION

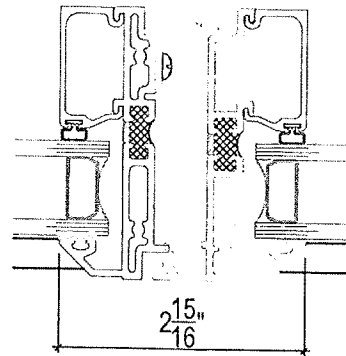

2 - STEEL REP. FIXED  
@ SILL

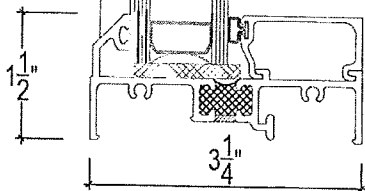

4 - STEEL REP. VENT  
@ HORIZONTAL MULLION

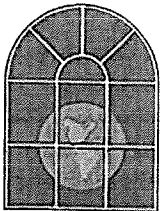
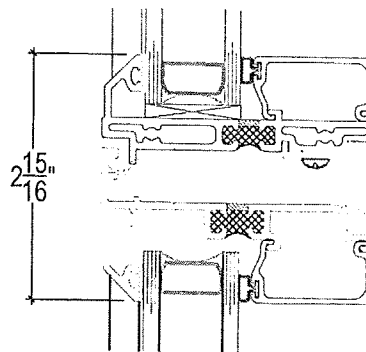

**UNIVERSAL WINDOW  
AND DOOR, LLC.**

303 Mechanic Street  
Marlborough, MA 01752  
800-633-0108 508-481-2850  
www.universalwindow.com

**UNIVERSAL 700 STEEL REPLICA  
FIXED W/ CENTER VENT**

DATE:  
11-03-2015

DWG #:  
UNI-700-0004

REV:  
A

SCALE: NTS

DRAWING FOR FAMILIARIZATION ONLY.  
ACTUAL DETAIL MAY VARY



700 STEEL REPLICA WINDOW

SHOWN w/ 3PC MULLION FXD/FXD

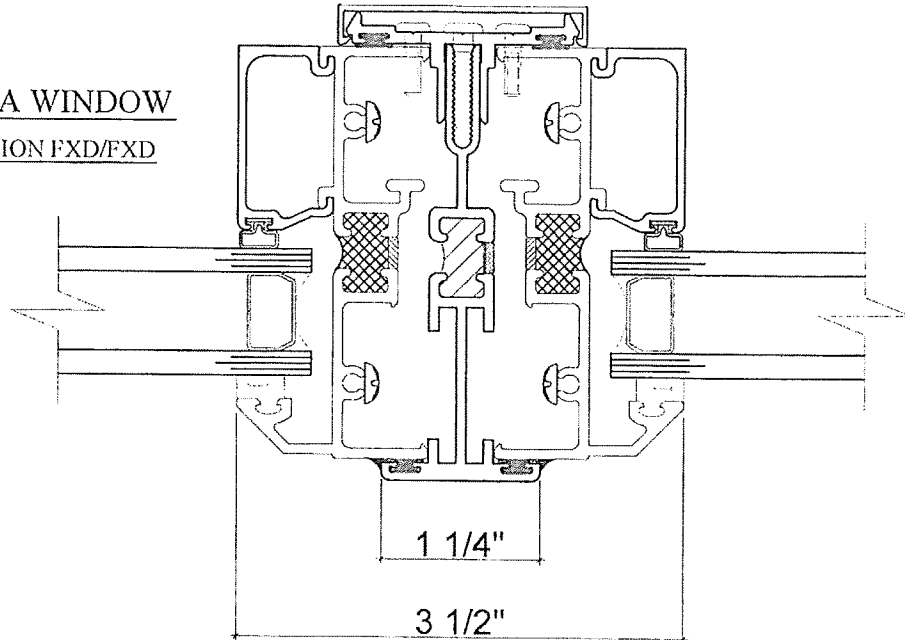

700 STEEL REPLICA WINDOW

SHOWN w/ 3PC MULLION FXD/VENT

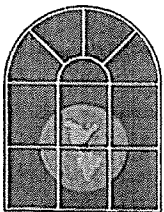
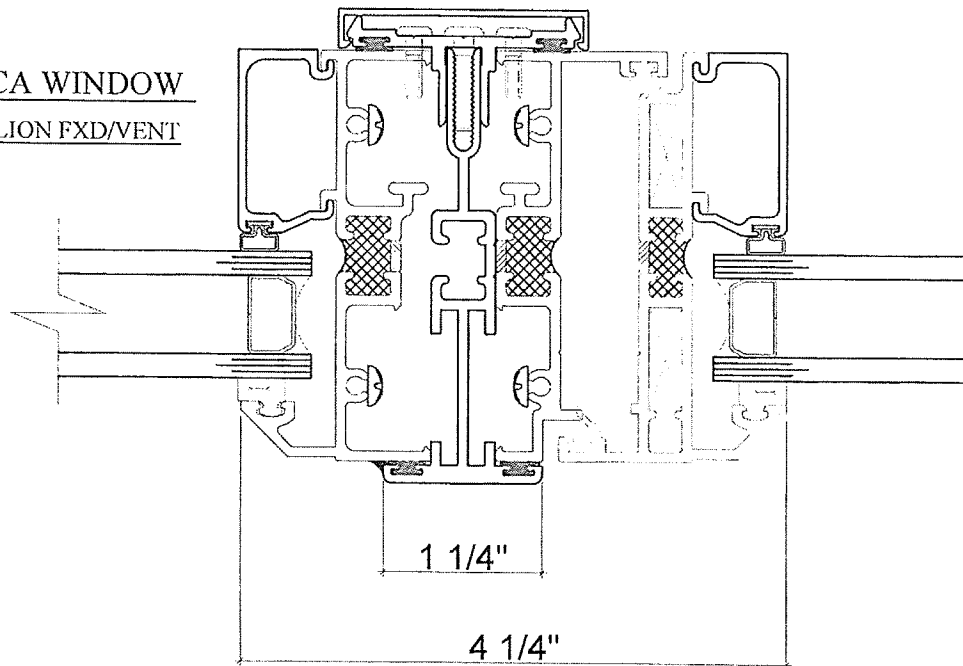

**UNIVERSAL WINDOW  
AND DOOR, LLC.**

303 Mechanic Street  
Marlborough, MA 01752  
800-633-0108  
508-481-2850  
www.universalwindow.com

**UNIVERSAL 700 STEEL REPLICA  
3PC MULLIONS**

DATE:  
11-03-2015

DWG #:  
UNI-700-0005

REV:

SCALE: NTS

DRAWING FOR FAMILIARIZATION  
ONLY, ACTUAL DETAIL MAY VARY

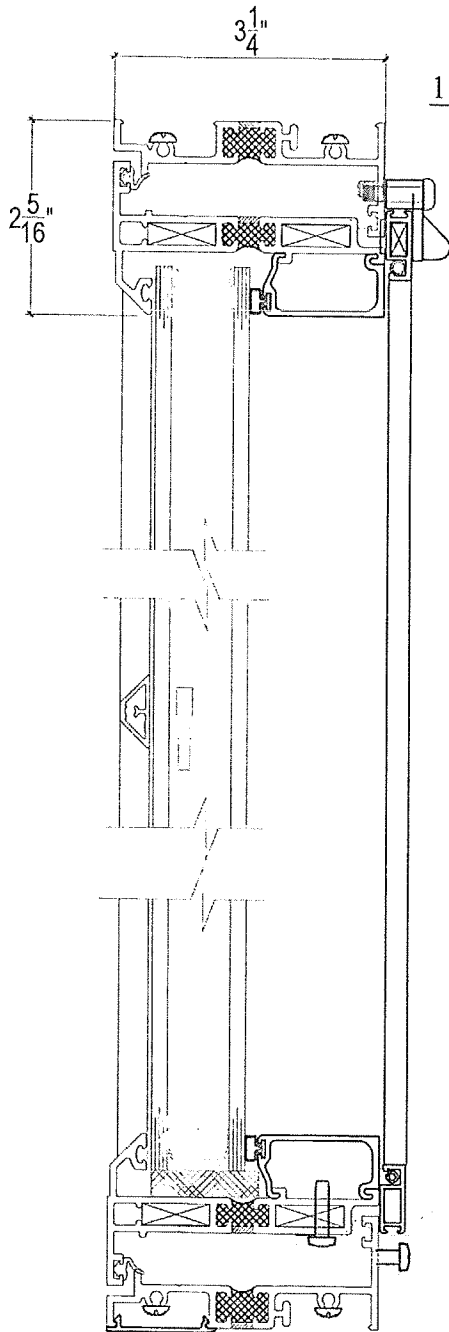

1 - STEEL REP. VENT  
@ HEAD

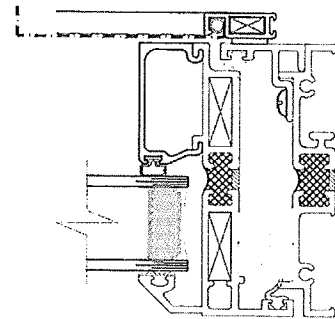
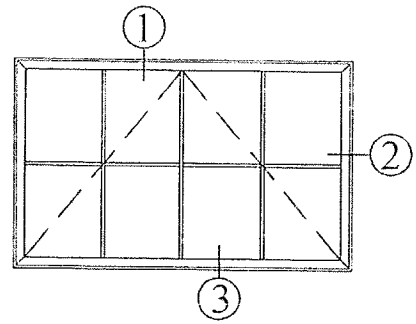

3 - STEEL REP. VENT  
@ JAMB  
JAMB SHOWN WITH  
OPTIONAL STRAP ANCHOR

2 - STEEL REP. VENT  
@ SILL

OPTIONAL CAULK STOP

DRAWING FOR FAMILIARIZATION ONLY, ACTUAL DETAIL MAY VARY

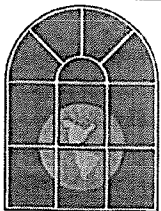

**UNIVERSAL WINDOW AND DOOR, LLC.**

303 Mechanic Street  
Marlborough, MA 01752  
800-633-0108 508-481-2850  
www.universalwindow.com

**UNIVERSAL 700 STEEL REPLICA SINGLE VENT W/ ROTO OPEN**

DATE: 11-03-2015

DWG #: UNI-700-0006

REV: A

SCALE: NTS

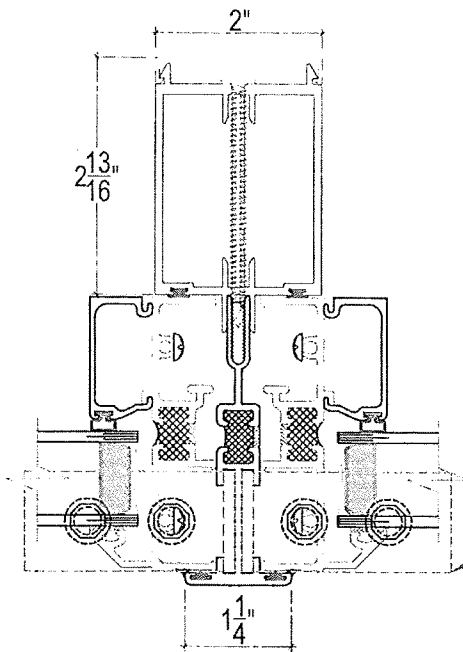

INSTALLATION  
CLIP USE 3  
HEAD AND CILL  
  
TYP FOR 2PC  
MULLION

STRUCTURAL 2 INCHES  
TUBE MULLION

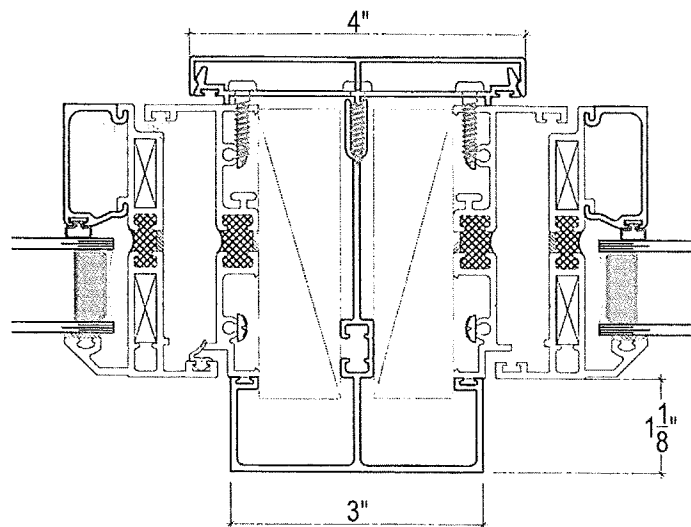

3 INCHES MULLION

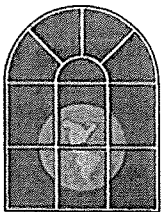

**UNIVERSAL WINDOW  
AND DOOR, LLC.**

303 Mechanic Street  
Marlborough, MA 01752  
800-633-0108 508-481-2850  
www.universalwindow.com

**UNIVERSAL 700  
HEAVY 3 INCHES MULLION**

DATE:  
11-03-2015

DWG #:  
UNI-700-0007

REV:  
A

SCALE: NTS

DRAWING FOR FAMILIARIZATION  
ONLY, ACTUAL DETAIL MAY VARY



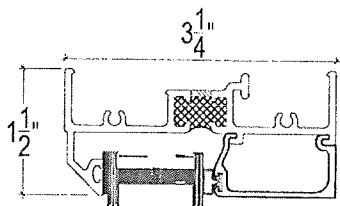

HEAD

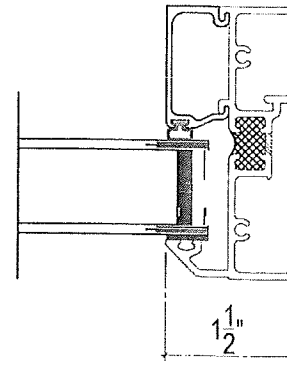

JAMB DETAIL

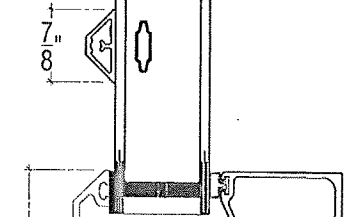

MEETING RAIL

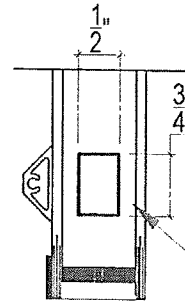

OPTIONAL  
SILL DETAIL

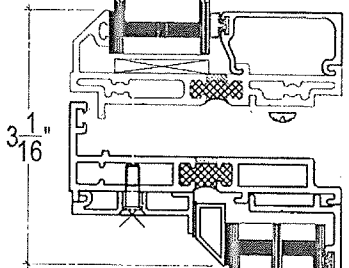

OPTIONAL TRIPLE  
GLAZE

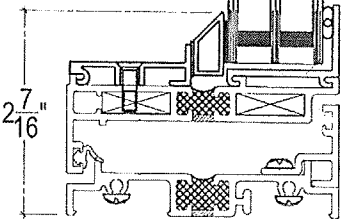

SILL

CAY HANDLE SHOWN  
OPTIONAL ROTARY  
OPERATOR AVAILABLE

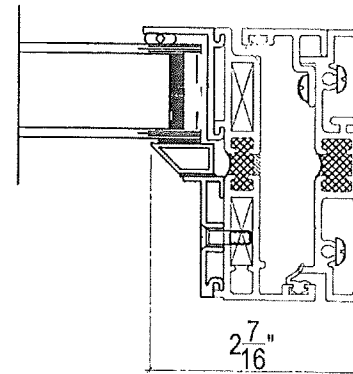

JAMB DETAIL

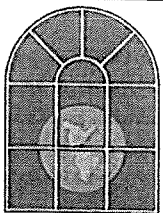

**UNIVERSAL WINDOW  
AND DOOR, LLC.**

303 Mechanic Street  
Marlborough, MA 01752  
800-633-0108 508-481-2850  
www.universalwindow.com

**UNIVERSAL 700  
SIMULATED DH**

DATE:  
11-03-2015

DWG #:  
UNI-700-0008

REV:  
A

SCALE: NTS

DRAWING FOR FAMILIARIZATION  
ONLY, ACTUAL DETAIL MAY VARY

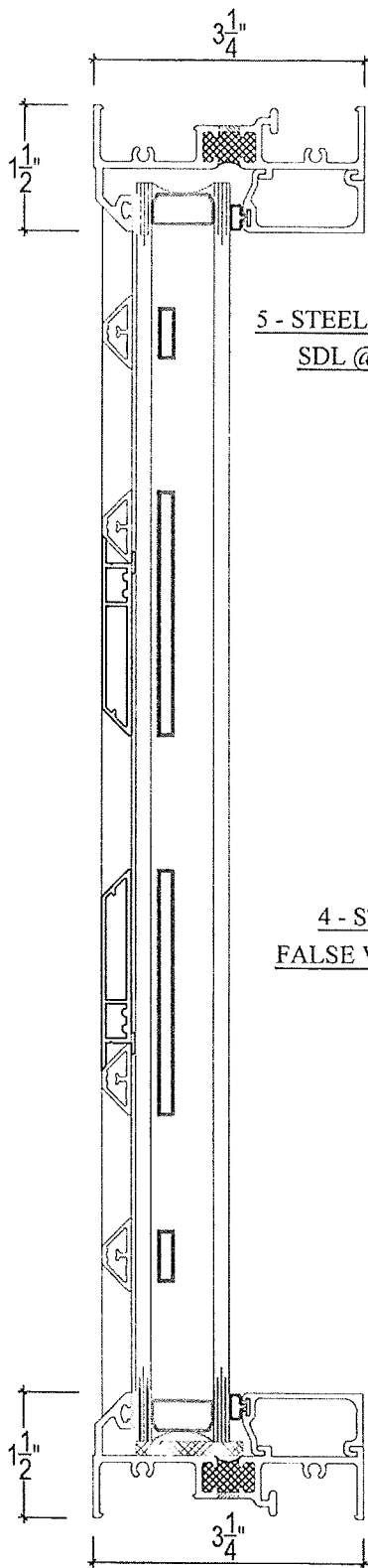

1 - STEEL REP. FIXED @ HEAD

5 - STEEL REP. STANDARD SDL @ MULLION

4 - STEEL REP. FALSE VENT PROFILE

2 - STEEL REP. FIXED @ SILL

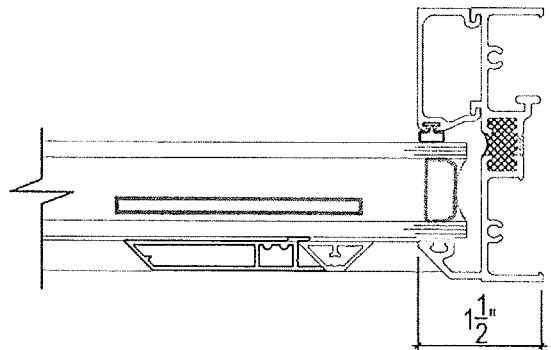
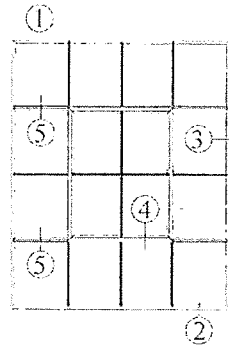

3 - STEEL REP. FALSE VENT PROFILE @ JAMB

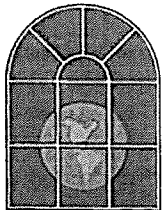

**UNIVERSAL WINDOW AND DOOR, LLC.**

303 Mechanic Street  
 Marlborough, MA 01752  
 800-633-0108 508-481-2850  
 www.universalwindow.com

**UNIVERSAL 700 STEEL REPLICA  
 FIXED SIMULATED VENT**

DATE: 11-03-2015

DWG #: UNI-700-0009

REV: A

SCALE: NTS

DRAWING FOR FAMILIARIZATION ONLY.  
 ACTUAL DETAIL MAY VARY





SECTION 1:

A. With respect to Commercial Façade Grant improvements, the CITY shall reimburse OWNER/LESSEE for the cost of improvements to the OWNER/LESSEE's property at the rate of up to twenty five (25%) of the cost of Routine Maintenance Improvements, up to fifty percent (50%) of the cost of Historic Preservation Improvements and other Building Improvements, and up to one hundred percent (100%) of the cost of fees for Architectural Services pertaining to such improvements, provided that the total reimbursement for eligible improvements and architectural services shall not exceed the amount shown in Exhibit I, "Total Reimbursement Amounts", attached hereto.

B. With respect to Residential Façade Grant improvements, the CITY shall reimburse OWNER/LESSEE for the cost of improvements to the OWNER/LESSEE's property at the rate of up to fifty percent (50%) of the cost of Historic Preservation Improvements, and up to one hundred percent (100%) of the cost of fees for Architectural Services pertaining to such improvements, provided that the total reimbursement for eligible improvements and architectural services shall not exceed the amount shown in Exhibit I, "Total Reimbursement Amounts", attached hereto.

The actual total reimbursement amounts per this Agreement shall not exceed the amounts shown in Exhibit I. The improvement costs which are eligible for City reimbursement include all labor, materials, equipment and other contract items necessary for the proper execution and completion of the work as shown on the plans, design drawings, specifications and estimates approved by the City. Such plans, design drawings, specifications and estimates are attached hereto as Exhibit II.

SECTION 2: No improvement work shall be undertaken until its design has been submitted to and approved by the City Council. Following approval, the OWNER/LESSEE shall contract for the work and shall commence and complete all such work within the Program Year, ending April 30.

SECTION 3: The Director of Community Development shall periodically review the progress of the contractor's work on the facade improvement pursuant to this Agreement. Such inspections shall not replace any required building permit inspection. All work which is not in conformance with the approved plans, design drawings and specifications shall be immediately remedied by the OWNER/LESSEE and deficient or improper work shall be replaced and made to comply with the approved plans, design drawings and specifications and the terms of this Agreement.

SECTION 4: Upon completion of the improvements and upon their final inspection and approval by the Director of Community Development, the OWNER/LESSEE shall submit to the CITY a properly executed and notarized contractor statement showing the full cost of the work as well as each separate component amount due to the contractor and each and every subcontractor involved in furnishing labor, materials or equipment in the work. In addition, the OWNER/LESSEE shall submit to the CITY proof of payment of the contract cost pursuant to the contractor's statement and final lien waivers from all contractors and subcontractors. The OWNER/LESSEE shall also submit to the CITY a copy of the architect's statement of fees for professional services for preparation of plans and specifications. The CITY shall, within fifteen (15) days of receipt of the contractor's statement, proof of payment and lien waivers, and the architect's statement, issue a check to the OWNER/LESSEE as reimbursement, subject to the limitations set forth in Exhibit "I".

In the alternative, at its sole discretion, CITY may reimburse OWNER/LESSEE in two payments. The first reimbursement may be made only 1) upon completion of work representing 50% or more of the maximum reimbursement specified in Exhibit I hereof ; 2) upon receipt by CITY of the architect's invoices, contractor's statements, invoices, proof of payment and notarized final lien waivers for the completed work; and 3) upon a determination by the Director of Community Development that the remainder of the work is expected to be delayed for thirty days or more following completion of the initial

work due to weather, availability of materials, or other circumstances beyond the control of the OWNER/LESSEE. The second, final reimbursement payment shall be made by CITY only upon submittal of all necessary documents as described herein.

SECTION 5: If the OWNER/LESSEE or his contractor fails to complete the improvement work provided for herein in conformity with the approved plans, design drawings and specifications and the terms of this Agreement, or if the improvements are not completed by the end of the Program Year on April 30, this Agreement shall terminate and the financial obligation on the part of the CITY shall cease and become null and void. The CITY may, at its sole discretion, grant a single one-year extension to the end of the following program year due to unforeseen circumstances that have prevented the completion of the project.

SECTION 6: Upon completion of the improvement work pursuant to this Agreement and for a period of five (5) years thereafter, the OWNER/LESSEE shall be responsible for properly maintaining such improvements in finished form and without change or alteration thereto, as provided in this Agreement, and for the said period of five (5) years following completion of the construction thereof, the OWNER/LESSEE shall not enter into any Agreement or contract or take any other steps to alter, change or remove such improvements, or the approved design thereof, nor shall OWNER/LESSEE undertake any other changes, by contract or otherwise, to the improvements provided for in this Agreement unless such changes are first submitted to the Director of Community Development, and any additional review body designated by the Director, for approval. Such approval shall not be unreasonably withheld if the proposed changes do not substantially alter the original design concept of the improvements as specified in the plans, design drawings and specifications approved pursuant to this Agreement. If requested by the CITY, OWNER/LESSEE agrees to execute and record a restrictive covenant regarding the maintenance of improvements completed per this agreement.



SECTION 7: The OWNER/LESSEE releases the CITY from, and covenants and agrees that the CITY shall not be liable for, and covenants and agrees to indemnify and hold harmless the CITY and its officials, officers, employees and agents from and against, any and all losses, claims, damages, liabilities or expenses, of every conceivable kind, character and nature whatsoever arising out of, resulting from or in any way connected with directly or indirectly with the facade improvement(s), including but not limited to actions arising from the Prevailing Wage Act (820 ILCS 30/0.01 et seq.) The OWNER/LESSEE further covenants and agrees to pay for or reimburse the CITY and its officials, officers, employees and agents for any and all costs, reasonable attorneys' fees, liabilities or expenses incurred in connection with investigating, defending against or otherwise in connection with any such losses, claims, damages, liabilities, or causes of action. The CITY shall have the right to select legal counsel and to approve any settlement in connection with such losses, claims, damages, liabilities, or causes of action. The provisions of this section shall survive the completion of said facade improvement(s).

SECTION 8: Nothing herein is intended to limit, restrict or prohibit the OWNER/LESSEE from undertaking any other work in or about the subject premises which is unrelated to the facade improvement provided for in this Agreement.

SECTION 9: This Agreement shall be binding upon the CITY and upon the OWNER/LESSEE and its successors, to said property for a period of five (5) years from and after the date of completion and approval of the facade improvement provided for herein. It shall be the responsibility of the OWNER/LESSEE to inform subsequent OWNER(s)/LESSEE(s) of the provisions of this Agreement.

IN WITNESS THEREOF, the parties hereto have executed this Agreement on the date first appearing above.

**OWNER/LESSEE**

**CITY OF ST. CHARLES**

\_\_\_\_\_

\_\_\_\_\_

**Mayor**

**ATTEST:** \_\_\_\_\_

**City Clerk**

**EXHIBIT "I"**

**Total Reimbursement Amounts**

**Commercial Façade Grants:**

	<b>Total Estimated Cost</b>	<b>Reimbursement Percentage</b>	<b>Total Maximum Grant Amount</b>
<b>Routine Maintenance Improvements</b>	\$	25%	\$
<b>Historic Preservation Improvements</b>	\$ 45,178.00	50%	\$ 18,572.60
<b>Building Improvements</b>	\$	50%	\$
<b>Architectural Services</b>	\$	100% (not to exceed \$4000)	\$
<b>TOTAL</b>	\$ 45,178.00	-	\$ 18,572.60

**Residential Façade Grants:**

	<b>Total Estimated Cost</b>	<b>Reimbursement Percentage</b>	<b>Total Maximum Grant Amount</b>
<b>Historic Preservation Improvements</b>	\$	50%	\$
<b>Architectural Services</b>	\$	100% (not to exceed \$2000)	\$
<b>TOTAL</b>	\$	-	\$



**EXHIBIT “II”**

**Plans, Design drawings, Specifications and Estimates**

Attachments:

Proposal from Window City, Inc., dated 8/15/17