

<b>HISTORIC PRESERVATION COMMISSION AGENDA ITEM EXECUTIVE SUMMARY</b>				
 <b>CITY OF ST. CHARLES</b> ILLINOIS • 1834	<b>Agenda Item Title/Address:</b>	COA: 217 Cedar Ave		
	<b>Significance:</b>	Contributing		
	<b>Petitioner:</b>	Baker Memorial Church		
	<b>Project Type:</b>	Doors		
	<b>PUBLIC HEARING</b>		<b>MEETING 2/15/23</b>	<b>X</b>
<b>Agenda Item Category:</b>				
	Preliminary Review		Grant	
X	Certificate of Appropriateness (COA)		Other Commission Business	
	Landmark/District Designation		Commission Business	
<b>Attached Documents:</b>		<b>Additional Requested Documents:</b>		
Application, door information, photo, architectural survey				
<b>Project Description:</b>				
<ul style="list-style-type: none"> <li>A man door was installed in the middle of the garage door.</li> </ul>				
<b>Staff Comments:</b>				
Work was done without a permit. Commission tabled the item at the last meeting until the applicant could be present. Commission discussed adding siding to the garage door to make the building look more like a shed.				
<b>Recommendation / Suggested Action:</b>				
<ul style="list-style-type: none"> <li>Provide feedback and recommendation on approval of the COA</li> </ul>				

**BAKER MEMORIAL  
UNITED METHODIST CHURCH**

Experience Christianity for Today's World

Pastor Mary Zajac, *Elder*      Pastor Kim Neace, *Deacon*

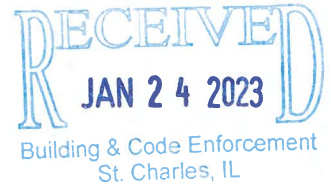

January 13, 2023

City of St. Charles  
Building & Code Enforcement Division  
2 E. Main Street

Re: 217 Cedar Avenue, St. Charles, IL 60174  
To whom it may concern,

Please find enclosed a drawing of the work done at 217 Cedar Ave. and a check for \$200.00 for the required building permit. Repairs were made to an overhead garage door that was broken and stuck partially open, posing a safety risk to passers-by and those utilizing the garage.

Please direct further questions regarding this matter to:

John Stumpf, Trustee  
c/o Baker Memorial United Methodist Church  
307 Cedar Avenue  
St. Charles, IL 60174

Thank you,

  
Mandy Hale  
Director of Administration



307 Cedar Avenue | St. Charles, Illinois 60174 | office: 630.584.6680 | bakermemorialchurch.org

**SERVING CHRIST HERE, NEAR, & FAR AWAY**

RECEIVED  
JAN 24 2023  
Building & Code Enforcement  
St. Charles, IL

### SCOPE OF WORK

- EXISTING GARAGE DOOR WAS HANGING BROKEN AT TOP AND NEEDED REPAIR IN ORDER TO CLOSE PROPERLY AND REDUCE FALL RISK. WORK PERFORMED INCLUDED REPLACING A BROKEN SPRING, REPLACING WHEEL GUIDES, BROKEN HINGES, AND DOOR JAM.
- EXISTING DOOR WAS IN EXCESS OF 200 LBS AND POSED A SAFETY RISK, NEEDING IMMEDIATE REPAIR.
- GARAGE IS NOT USED TO PARK CARS AND IT WAS DECIDED TO INSTALL A DOOR TO SERVE PEDESTRIANS AND SMALL YARD VEHICLES/EQUIPMENT.
- ALL WORK WAS PERFORMED BY VOLUNTEERS.

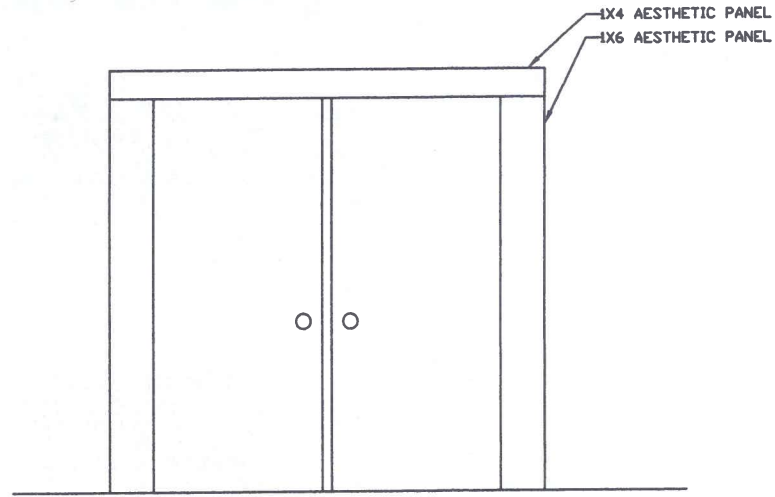

EXTERIOR

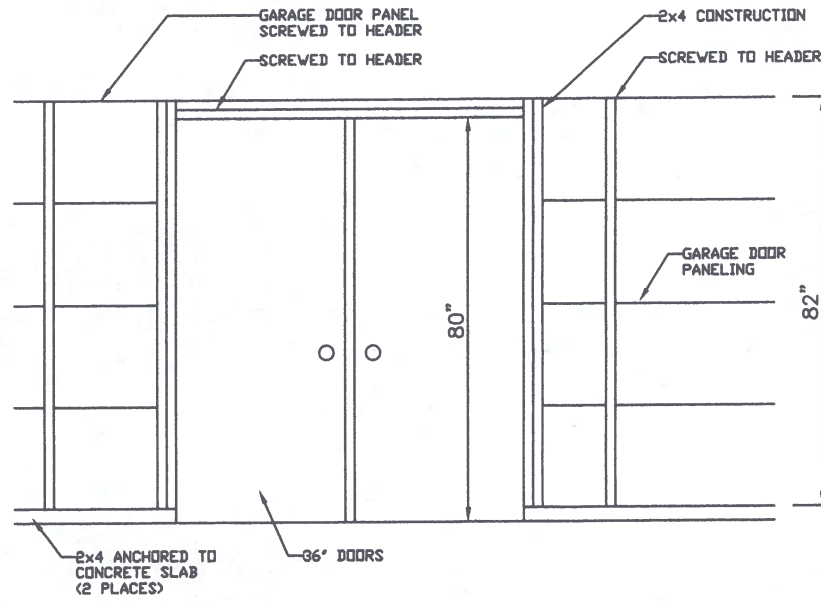

INTERIOR



12.8.2022 11:56



ST. CHARLES HISTORIC PRESERVATION COMMISSION

**ARCHITECTURAL SURVEY**  
**ST. CHARLES CENTRAL DISTRICT**  
**ST. CHARLES, ILLINOIS**

DIXON ASSOCIATES / ARCHITECTS

**ARCHITECTURAL INTEGRITY**

	1	2	3
<input type="checkbox"/> Unaltered	<input type="checkbox"/>	<input type="checkbox"/>	<input type="checkbox"/>
<input type="checkbox"/> Minor Alteration	<input type="checkbox"/>	<input type="checkbox"/>	<input type="checkbox"/>
<input type="checkbox"/> Major Alteration	<input type="checkbox"/>	<input type="checkbox"/>	<input type="checkbox"/>
<input checked="" type="checkbox"/> Additions	<input checked="" type="checkbox"/>	<input type="checkbox"/>	<input type="checkbox"/>
Sensitive to original	<input checked="" type="checkbox"/>	<input type="checkbox"/>	<input type="checkbox"/>
Insensitive to original	<input type="checkbox"/>	<input type="checkbox"/>	<input type="checkbox"/>

1: first floor; 2: upper floors; 3: roof/cornice

**ARCHITECTURAL SIGNIFICANCE**

Significant

Contributing

Non-Contributing

**BUILDING CONDITION**

Excellent: Well-maintained

Good: Minor maintenance needed

Fair: Major repairs needed

Poor: Deteriorated

**ARCHITECTURAL DESCRIPTION**

**Style:** Greek Revival

**Date of Construction:** 1846

**Source:** St. Charles Historical Museum

**Features:**

Two story structure with one story addition at south. Front gabled roof. Stucco exterior filled in fan light and greatly affected the appearance.

Historically the structure is significant.

Dan Otto, professional historic carpenter, assessed the home in 2017. He determined that the structure is in remarkable condition and that restoration would require only cosmetic work and nothing structural in nature.



**Address:**

217 East Cedar Avenue

**Representation in Existing Surveys:**

Federal

State

County

Local

**Block No.** 42

**Building No.** 5

**SURVEY DATE:**

MAY 1994

**ROLL NO.** 14

**NEGATIVE NO.** 3