 <p>CITY OF ST. CHARLES ILLINOIS • 1834</p>	HISTORIC PRESERVATION COMMISSION AGENDA ITEM EXECUTIVE SUMMARY			
	Agenda Item Title/Address:	COA: 307 W Main St.		
	Significance:	Non-Contributing		
	Petitioner:	Silas Patel		
	Project Type:	Door Shutter		
	PUBLIC HEARING		MEETING 4/19/23	X
Agenda Item Category:				
	Preliminary Review		Grant	
X	Certificate of Appropriateness (COA)		Other Commission Business	
	Landmark/District Designation		Commission Business	
Attached Documents:			Additional Requested Documents:	
Application, information, architectural survey				
Project Description:				
<ul style="list-style-type: none"> Proposed is to install a security shutter over the front door for when the store is closed. <p>https://qmiusa.com/products/storesafe-overview/solid-aluminum-shutters/</p>				
Staff Comments:				
Recommendation / Suggested Action:				
<ul style="list-style-type: none"> Provide feedback and recommendation on approval of the COA 				

APPLICATION FOR COA REVIEW
HISTORIC PRESERVATION "CERTIFICATE OF APPROPRIATENESS"



COMMUNITY & ECONOMIC DEVELOPMENT DEPARTMENT / CITY OF ST. CHARLES

(630) 377-4443

To be filled out by City Staff

Permit # 2223 -- 00600 Date Submitted: 4/10/23 COA # _____ Admin. Approval: _____

APPLICATION INFORMATION

Address of Property: 307 W. Main St St Charles IL 60174

Use of Property: Commercial, business name: Shell Gas Station

Residential Other: _____

RECEIVED
APR 10 2023
Building & Code Enforcement
St. Charles, IL

Project Type:

- Exterior Alteration/Repair
 - Windows
 - Doors
 - Siding - Type: _____
 - Masonry Repair
 - Other _____
- Awnings/Signs

- New Construction
 - Primary Structure
 - Additions
 - Deck/Porch
 - Garage/Outbuilding
 - Other _____

- Demolition
 - Primary Structure
 - Garage/Outbuilding
 - Other _____
- Relocation of Building

Description:

Installation of Security shutter of the front door

Applicant Information:

Name (print): SHARISH PATIL
 Address: 307 W. MAIN ST, ST CHARLES
 Phone: 630-965-2598
 Email: cebh41168@g.mau.com

Applicant is (check all that apply):

- Property Owner
- Business Tenant
- Project contractor
- Architect/Designer

Property Owner Information (if not the Applicant)

Name (print): NICKY IMERSON
 Address: 307 W. MAIN ST ST CHARLES
 Signature: [Signature]

APPLICANT/AUTHORIZED AGENT SIGNATURE

I agree that all work shall be in accordance with the plans, specifications and conditions which accompany this application, and I have read and understand the Historic Preservation COA General Conditions.

Signature: [Signature] Date: 4-10-23

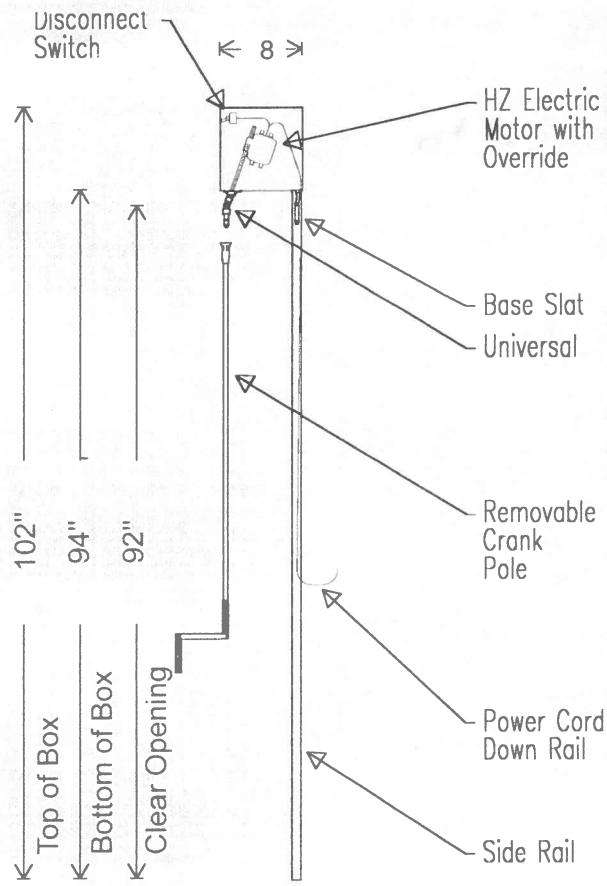
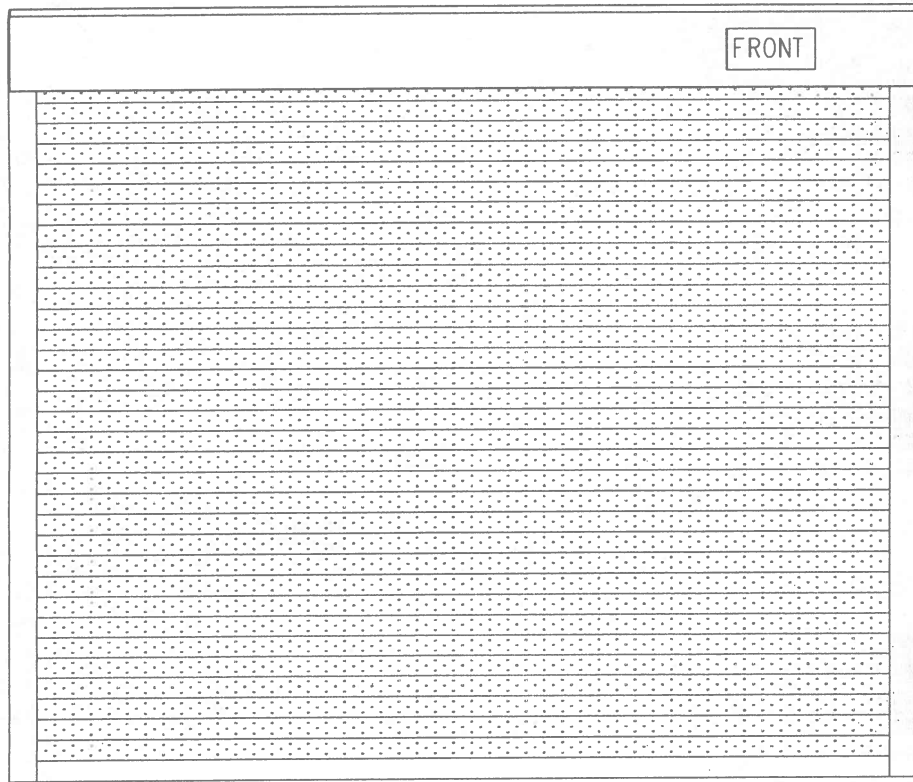

SECTION

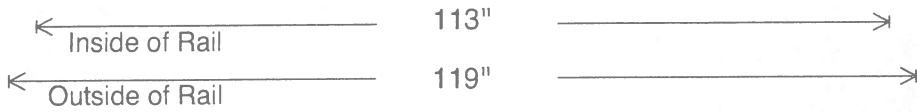

ELEVATION

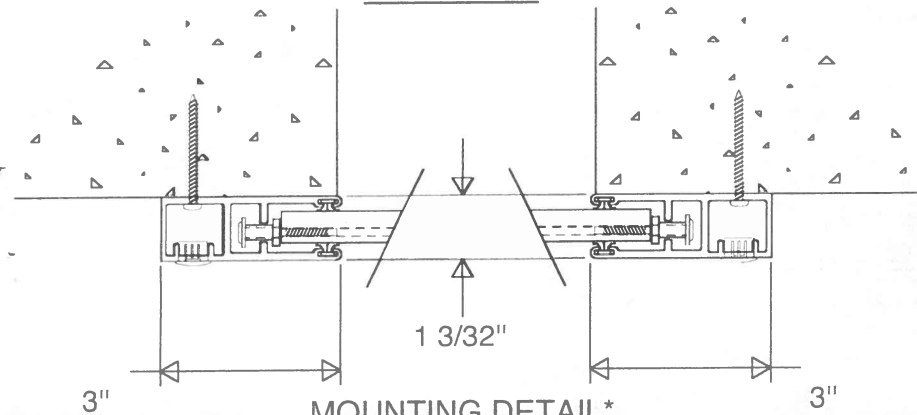

MOUNTING DETAIL *

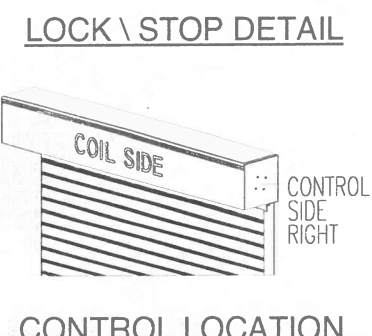

CONTROL LOCATION

By: Approved for manufacture
 Approved for manufacture as noted below
 Make changes as noted below and resubmit

Date: _____

Seacoast Application: YES NO

Hurricane Rated:* YES NO

Width	Inside of Rail:	113"	_____
	Outside of Rail:	119"	_____
Height	Clear Opening:	92"	_____
	Bottom of Box:	94"	_____
	Top of Box:	102"	_____
	Housing Size:	8	_____
Color	Rail:	CLR ANODIZED	_____
	Housing:	CLR ANODIZED	_____
	Slat:	CLR ANODIZED	_____
	Base Slat:	CLR ANODIZED	_____
Curtain	Slat Type:	AL7-E	_____
	Slat Style:	Punch 51	_____
	Curtain Weight:	81.0 lbs.	_____
Control	Control Side:	RIGHT	_____
	Control Type:	EM-SA-530-HZ-O	_____
Mounting	Left Rail:	SURFACE DRILLED	_____
	Ø1: 1/2" Ø2: 3/16" ⌀ ~12" ⌀		
	Right Rail:	SURFACE DRILLED	_____
	Ø1: 1/2" Ø2: 3/16" ⌀ ~12" ⌀		
	Mounting Style:	WINDOW	_____

#: **199324-1** **JTO** Date: **03/21/23**

Customer: **National Security Solutio**

Job Name: **Silas Patel**

Shutter #: **4 of 4** QTY: **1**

National Security Solutions

AMOUNT DUE **\$4,500.00**

Silas Patel
307 W Main St
St. Charles, IL 60174

CONTACT US
15808 Clifton Park Ave
Markham, IL 60428

☎ (630) 965-2598
✉ SilasPatel108@gmail.com

☎ (773) 778-8053
✉ Sales@nationalsecuritysolutions.net

INVOICE

Services	qty	unit price	amount
Shutters - Shutter Rolling Shutter Box Rail Slat Color: Anodized Slat type: AL 7 End Retention Punch 51 Size: 119 x 102 Control: Motor w/ Manual Override Power: RDR Buildout: 2 x 4 x 94 - 2 pieces Sill: Location: Gas Station Front Door Additional Options: Keypad	1.0	\$4,500.00	\$4,500.00

Total **\$4,500.00**

Thank you for choosing NSS! We appreciate your business and your trust in us.



ST. CHARLES HISTORIC PRESERVATION COMMISSION

ARCHITECTURAL SURVEY ST. CHARLES CENTRAL DISTRICT ST. CHARLES, ILLINOIS

DIXON ASSOCIATES / ARCHITECTS

ARCHITECTURAL INTEGRITY

	1	2	3
<input type="checkbox"/> Unaltered	<input type="checkbox"/>	<input type="checkbox"/>	<input type="checkbox"/>
<input type="checkbox"/> Minor Alteration	<input type="checkbox"/>	<input type="checkbox"/>	<input type="checkbox"/>
<input type="checkbox"/> Major Alteration	<input type="checkbox"/>	<input type="checkbox"/>	<input type="checkbox"/>
<input checked="" type="checkbox"/> Additions	<input checked="" type="checkbox"/>	<input type="checkbox"/>	<input type="checkbox"/>
Sensitive to original	<input type="checkbox"/>	<input type="checkbox"/>	<input type="checkbox"/>
Insensitive to original	<input checked="" type="checkbox"/>	<input type="checkbox"/>	<input type="checkbox"/>

1: first floor; 2: upper floors; 3: roof/cornice

BUILDING CONDITION

- Excellent: Well-maintained
- Good: Minor maintenance needed
- Fair: Major repairs needed
- Poor: Deteriorated

ARCHITECTURAL DESCRIPTION

Style: Modern

Date of Construction: Post 1944

Source: A Field Guide to American Houses

Features:

Low gabled ranch style building. Mansard canopy over gas pumps added in late 1980's.

ARCHITECTURAL SIGNIFICANCE

- Significant
- Contributing
- Non-Contributing



Address:

307 West Main Street

Representation in Existing Surveys:

- Federal
- State
- County
- Local

Block No. 9

Building No. 3

SURVEY DATE:

MAY 1994

ROLL NO. 7

NEGATIVE NO. 18



ST. CHARLES HISTORIC PRESERVATION COMMISSION

ARCHITECTURAL SURVEY ST. CHARLES CENTRAL DISTRICT ST. CHARLES, ILLINOIS

DIXON ASSOCIATES / ARCHITECTS

CONTINUATION SHEET NO: 1



Address:

307 West Main Street

Remarks:

West Elevation

Block No. 9

Building No. 3

ROLL NO. 12

NEGATIVE NO. 21



Address:

307 West Main St.

Remarks:

Photo taken 10/2022

Block No. 9

Building No. 3

ROLL NO.

NEGATIVE NO.



ST. CHARLES HISTORIC PRESERVATION COMMISSION

ARCHITECTURAL SURVEY
ST. CHARLES CENTRAL DISTRICT
ST. CHARLES, ILLINOIS

DIXON ASSOCIATES / ARCHITECTS

CONTINUATION SHEET NO: 1



Address:

307 West Main St.

Remarks:

Photo taken 10/2022

ROLL NO.

NEGATIVE NO.

Block No. 9

Building No. 3

Address:

Remarks:

ROLL NO.

NEGATIVE NO.

Block No.

Building No.