 ST. CHARLES <small>SINCE 1834</small>	HISTORIC PRESERVATION COMMISSION AGENDA ITEM EXECUTIVE SUMMARY			
	Agenda Item Title/Address:	Eligibility for Historic District Designation: Millington Historic District		
	Proposal:	Designate the Millington Historic District		
	Petitioner:	Historic Preservation Commission		
Please check appropriate box (x)				
	PUBLIC HEARING 1/18/17	X	MEETING 1/18/17	X
AGENDA ITEM CATEGORY:				
	Certificate of Appropriateness (COA)		Façade Improvement Plan	
	Preliminary Review	X	Landmark/District Designation	
	Discussion Item		Commission Business	
ATTACHMENTS:				
Ordinance Criteria for Historic District Designation				
Historic District nomination form and attachments				
Architectural Survey pages				
Correspondence				
EXECUTIVE SUMMARY:				
<p>A Historic District nomination has been submitted for the proposed Millington Historic District, bound by State Street to the north, 5th Street to the east, Illinois Street to the south, and 7th Street to the west.</p> <p>The Commission reviewed the nomination on 12/21/16 and discussed updates to the Architectural Survey pages for structures located within the proposed district. The survey pages have been updated per the Commission's recommendations.</p>				
RECOMMENDATION / SUGGESTED ACTION:				
<p>Conduct the public hearing and close if all testimony has been taken.</p> <p>The landmark nomination is listed on the meeting agenda for consideration after the public hearing is closed.</p>				

St. Charles Zoning Ordinance – Criteria for Historic District Designation

17.32.070.C

The Historic Preservation Commission shall evaluate the proposed district for its eligibility as an historic district based on its overall historic and/or architectural significance, and the extent to which it meets the following criteria:

1. The area contains one (1) or more buildings, structures or sites meeting the criteria for landmark designation, and may also include other buildings, structures or sites which, although they may not qualify for individual landmark designation, contribute to the overall visual character of the area and to its architectural or historic significance.
2. The area is historically, economically or culturally significant to the development of St. Charles.
3. The area has sufficient integrity to convey the sense of a particular period in the history of the community.

CITY OF ST. CHARLES
TWO EAST MAIN STREET
ST. CHARLES, ILLINOIS 60174-1984



COMMUNITY & ECONOMIC DEVELOPMENT/PLANNING DIVISION PHONE: (630) 377-4443 FAX: (630) 377-4062

HISTORIC DISTRICT NOMINATION

Instructions:

To nominate an area for designation as a Historic District, complete this application and submit all required documentation to the Planning Division. Based on a review of the application by City staff and the Historic Preservation Commission, additional detailed information to support this application may be required.

The information you provide must be complete and accurate. If you have a question please call the Planning Division and we will be happy to assist you.

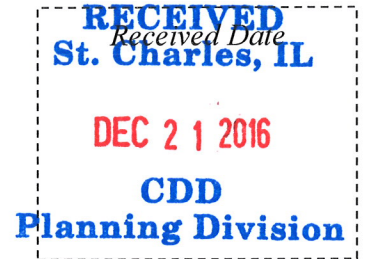

1. Proposed District Information:	District Name: Millington Historic District	
	Description of General Location: Bounded by State Street to the north, 5th Street to the east, Illinois Street to the south, 7th Street to the west	
2. Applicant:	Name St. Charles Historic Preservation Commission	Phone (630)377-4443
	Address 2 E Main St. St. Charles, IL 60174	Fax
		Email rcolby@stcharlesil.gov
3. Legal Description of District: (attach sheets if necessary) All that part of the City of St. Charles lying within those portions of Sections 27, 28, 33 and 34, Township 40 North, Range 8 East of the Third Principal Meridian, bounded and described as follows: Beginning at the point of intersection of the centerline of State Street with the center line of Fifth Street North; thence southerly along the center line of said Fifth Street to the point of intersection of the center line of Fifth Street South with the center line of Illinois Street; thence westerly along the centerline of said Illinois Street to the point of intersection of the centerline of Illinois Street with the centerline of Seventh Street South; thence northerly along the centerline of said Seventh Street to the point of intersection of the centerline of Seventh Street North with the centerline of State Street; thence easterly along the centerline of said State Street to the point of beginning; commonly known as Blocks 1, 2, 3, 4, 5, 6, 7 and 8 of Millington's Addition to St. Charles, recorded on August 15, 1842, in Record Book 2, Page 498, in the City of St. Charles, Kane County, Illinois. (Parcel Numbers Attached)		

4. **Boundary Map:** Attach an accurate map indicating the boundary of the proposed district.
5. **Descriptive Statement:** Attach a narrative statement describing the proposed district which includes the following information:
 - a. History of the area's development and its significance to the development of St. Charles
 - b. The architectural styles represented and years of construction of the structures within the area.
 - c. The integrity of the structures within the area, highlighting any properties that are designated landmarks and those that meet the criteria for landmark designation or otherwise contribute to the overall visual character of the area and its architectural or historic significance.
 - d. Any additional reasons the area should be designated as a Historic District.
6. **Documentation on Individual Properties:** This can be in the form of architectural surveys or other documentation. A photo, date of construction, architectural style, building materials, and description of architectural features should be provided for each property. The Historic Commission will review the submitted documentation to determine if the information is sufficient.
7. **List of Parcels and Property Owners:** Provide the parcel identification number, property address, owner's name, and mailing address for all properties included in the proposed district. Use the attached form or submit on a separate sheet.
8. **Petition of Support:** A petition supporting the nomination must be signed by at least 25% of the owners of record of the properties within the proposed district. Use the attached petition form. A petition is not required if the applicant is the Historic Preservation Commission.

I (we) certify that this application and the documents submitted with it are true and correct to the best of my (our) knowledge and belief.

Applicant or Authorized Agent

12-21-2016
Date

Descriptive Statement – Millington Historic District

I. Context

The Millington Historic District constitutes eight (8) square blocks directly west of the Central Historic District. The district is bounded by State Street to the north, 5th Street to the east, Illinois Street to the south, and 7th Street to the west. The district straddles W. Main Street, with four blocks on the north side and four blocks on the south side.

The district comprises the bulk of Millington's Addition to St. Charles, which was annexed into the City in 1842; blocks 1-8 are included in the district. The actual boundary of Millington's Addition stretches an additional block to the south, to Indiana St. Some of this additional area is part of the Moody-Millington Historic District.

A total of 51 properties lie within the district. Most properties are residential, with the exception of the nine (9) fronting W. Main St. The bulk of these properties were constructed as single-family homes but have been converted for use as commercial and office space. However, these properties have retained their original character and scale and are highly visible, prominent buildings on the west river bluff that serve as a transition into the downtown area.

II. History

Darwin Millington, born June 15, 1815, arrived to St. Charles from Ypsilanti, MI in 1837 with his father, Dr. Abel and his brother, Cicero. In 1838, Dr. Abel Millington purchased a large parcel of land on the west side of town from Gideon Young for \$8,000. The family developed and operated the first water-powdered flour mill on the west bank of the Fox River at the present-day site of the Hotel Baker. On February 1, 1840, the General Assembly enacted legislation authorizing, "Ira Minard, Reed Ferson, Bela T. Hunt, and Darwin Millington to construct, build, and continue a mill-dam across Fox River at the town of St. Charles." Darwin sold the mill to R.J. Haines around 1850. Darwin was a generous citizen, having donated the land for the West Town Park, now named Lincoln Park, as well as the adjoining land for construction of St. Patrick's Church. Darwin was also instrumental in bringing the St. Charles Branch Railroad to town in 1850.

In 1842, Darwin purchased from the US Government a quarter section of land west of and adjacent to the original town of St. Charles. The land was surveyed and subdivided into 9 blocks. The land was annexed into St. Charles on July 19, 1842 as Millington's Addition to St. Charles.

Around 1843, the house now addressed as 522 W Main St. was constructed or acquired by Darwin Millington on Block 4, Lot 5 of Millington's Addition. The location was known as "Millington's Hill". The house is a designated local Historic Landmark known as the Darwin Millington Homestead.

III. Survey Information

A survey of the Near West Side was commissioned by the City of St. Charles in 2003. The properties in the proposed district are included in the survey. The survey information was updated for this nomination to reflect changes that have occurred in the district since 2003.

The structures in the district date from 1838, with most construction occurring from the mid-1800s through the 1930s. Several architectural styles reflective of the period of construction are represented, including the National style, Greek Revival, Gothic Revival, Queen Anne, Colonial Revival, Prairie Four Square, and Craftsman.

In terms of architectural significance, 13 properties are rated as Significant, 22 properties are Contributing, and 16 properties are Non-Contributing.

The following are Significant structures identified in the survey:

- 500 Cedar St.
 - Craftsman, built 1911
- 521 Cedar St.
 - Craftsman, built 1925
- 522 Cedar St. (Landmark; see Section IV)
 - Colonial Revival, built circa 1912
- 606 Cedar St. (Landmark; see Section IV)
 - National, built circa 1837
- 621 Cedar St.
 - Shingle, built 1925
- 502 W Main St.
 - Queen Anne, built 1891
- 521 W Main St. (Landmark; see Section IV)
 - Gothic Revival, built 1866
- 522 W Main St. (Landmark; see Section IV)
 - Greek Revival, built circa 1843
- 612 W Main St.
 - Queen Anne, built 1894
- 619 W Main St.
 - Colonial Revival, built circa 1900
- 515 Walnut St.
 - Greek Revival, built 1875
- 19 S 5th St. (Landmark; see Section IV)
 - Greek Revival, built circa 1859
- 123 N. 6th St.
 - Queen Anne, built 1915

IV. Landmarks

Five (5) locally designated Historic Landmarks are located within the district:

1. Thomas Hanson Home – 522 Cedar St.
Built circa 1912
Colonial Revival
Designated 2000
The property was originally purchased in 1905 by Otto Frellsen, proprietor of the White Front Hotel. He and his partner William Drecher also owned a bowling alley and billiard

hall located on West Third St. The home was built between 1905 and 1912. The home was sold in 1912 to Thomas M. Hanson, who owned and operated Hanson Groceries.

2. Young-Marsden House – 606 Cedar St.

Built circa 1837

National style

Designated 2008

The house was most likely built by Gideon Young, who owned much of the property west of the Fox River. He is responsible for layout out the original boundaries of the west side of St. Charles. In 1838, Dr. Abel Millington purchased the entire property and began construction of a flour mill where Carroll Towers now stands. The house appears to be one of the first homes in St. Charles. The house shows signs of being part of the Underground Railroad, as there appear to be sleeping berths in the basement along with a well and tunnel that lead into the basement. Many early settlers to St. Charles were abolitionists and the community as known to be a stop on the Underground Railroad route. The property was sold to Roger Marsden in 1852. Marsden was a shoe and boot maker and owned a business with partner Thomas Metcalf. The home remained in the Marsden family through the turn of the 20th century.

3. Darwin Millington Homestead – 522 W. Main St.

Built circa 1843

National style with Greek Revival Influences

Designated 2016

Darwin Millington and his father, Dr. Abel Millington, constructed the first water powered flour mill on the Fox River. Darwin donated the land on which the old St. Patrick's Church was constructed, as well as land for the West Town Park, now named Lincoln Park. Darwin was also instrumental in bringing the St. Charles Branch Railroad to town in 1850.

4. Haines House – 521 W. Main St.

Built 1866

National style with Gothic Revival influences

Designated 2015

Charles Haines inherited the home from his father, Robert. Charles Haines served as the sixth mayor of St. Charles from 1889-1891. He funded construction of the Charles Haines School (demolished in 1956) and donated the land on which the Haines and Thomason middle schools now sit.

5. Dr. J.K. Lewis House – 19 S. 5th St.

Built circa 1859

Greek Revival

Designated 1998

The house is considered to be the only true example of the Greek Revival style in St. Charles. Dr. Lewis was the first and third mayor of St. Charles and practiced medicine in St. Charles un 1892. His daughter Genevieve served as the City's first librarian. Dr. Lewis sold the home in 1862 to Catherine Easter. The property was sold to Winfield F. Osgood in 1863. Mr. Osgood was an important local merchant and owner of the Osgood Building located at 11-15 E. Main St.

V. Attachments

- Millington's Addition to St. Charles Plat of Subdivision
- District Map with Architectural Survey Information

MILLINGTON'S

Addition. To St. Charles.

266,
1366
3232

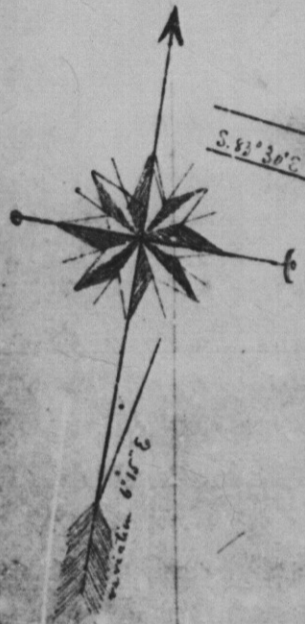

3	STATE	32	
66	27	66	66
57	5	3	66
717	6	7	8
66	66	66	66
3	COCKS	37	
66	2	3	66
1	2	3	4
66	6	7	8
66	66	66	66
3	MILLS	38	
66	1	2	3
1	2	3	4
66	6	7	8
66	66	66	66
3	WALKER	39	
66	1	2	3
1	2	3	4
66	6	7	8
66	66	66	66
3	ILLINOIS	40	
66	1	2	3
1	2	3	4
66	6	7	8
66	66	66	66

I do hereby certify that I have surveyed Millington's addition to the Town of Saint Charles in the County of St. Charles in the State of Illinois and that this map is a correct representation of the Tract, Blocks and lots in said addition.

John B. Bostow
Asst. Survr for P. S. Wagner
County Surveyor for
St. Charles County Illinois

July 17th 1842

State of Illinois
St. Charles County J. Leonard Howard a Justice of the Peace in and for the said county in the State aforesaid, Do hereby certify that Darius Millington is personally known appeared to before me this day in person and acknowledged himself to be proprietor of the addition to the Town of St. Charles as above described and platted and that the said addition was laid off agreeable to the within plat, shown under my hand and seal at my office in St. Charles in the County aforesaid this 17th day of July A.D. 1842.

J. Leonard Howard
Justice of the Peace

Filed August 15th 1842 at 9 o'clock A.M.
David Buchanan
Recorder

J. King
S. Kyle

This Indenture, in year of our said nation, John & King of St. Charles the first part and State aforesaid of part of the first hundred dollar of the second paraged have joint and bargain, sell and assigns five pieces or parcel of in the county of in the State of United States in Township, 30th Principal Merid commencing a Twenty five (25) thirty links (30) as east (175) links (34) 50ch. 70 fifty seven li chains and the containing in hundredths of a together with a and appurtena appertaining, a der and some and all the es demand or a first part, in above bargain and appurtena premises abo appurtenancy, part his heirs parties of the exccutors and bargain, and of the second

F

MILLINGTON'S ADDITION TO ST. CHARLES

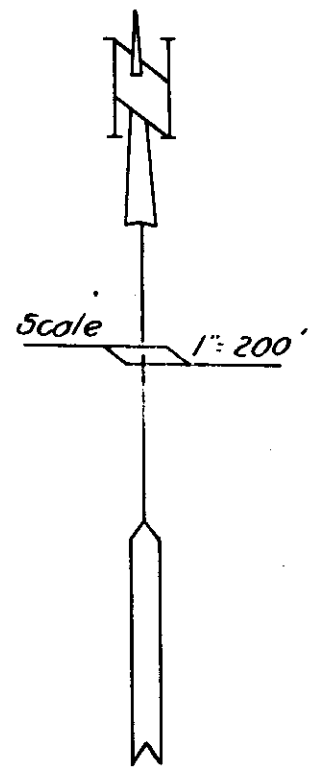
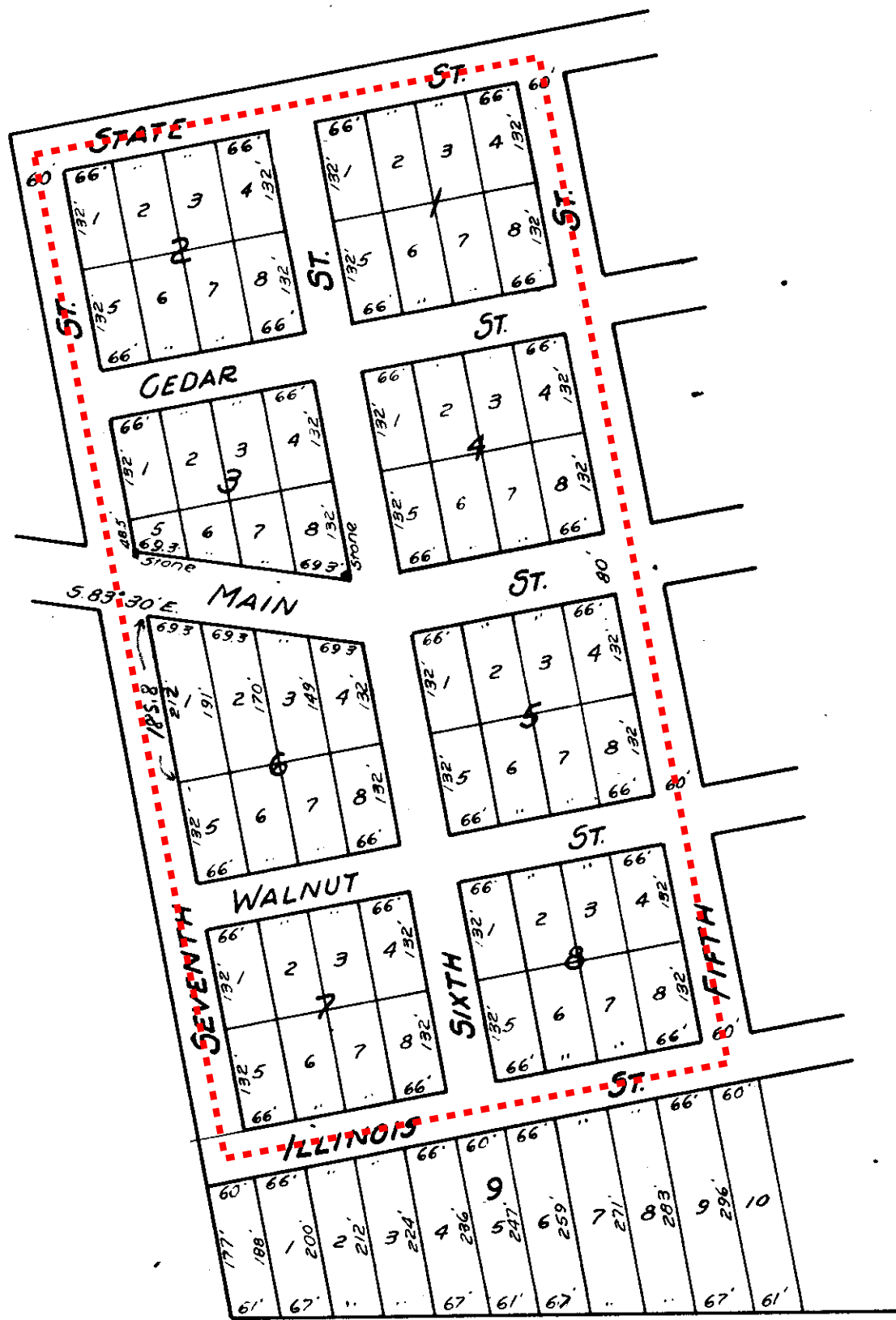





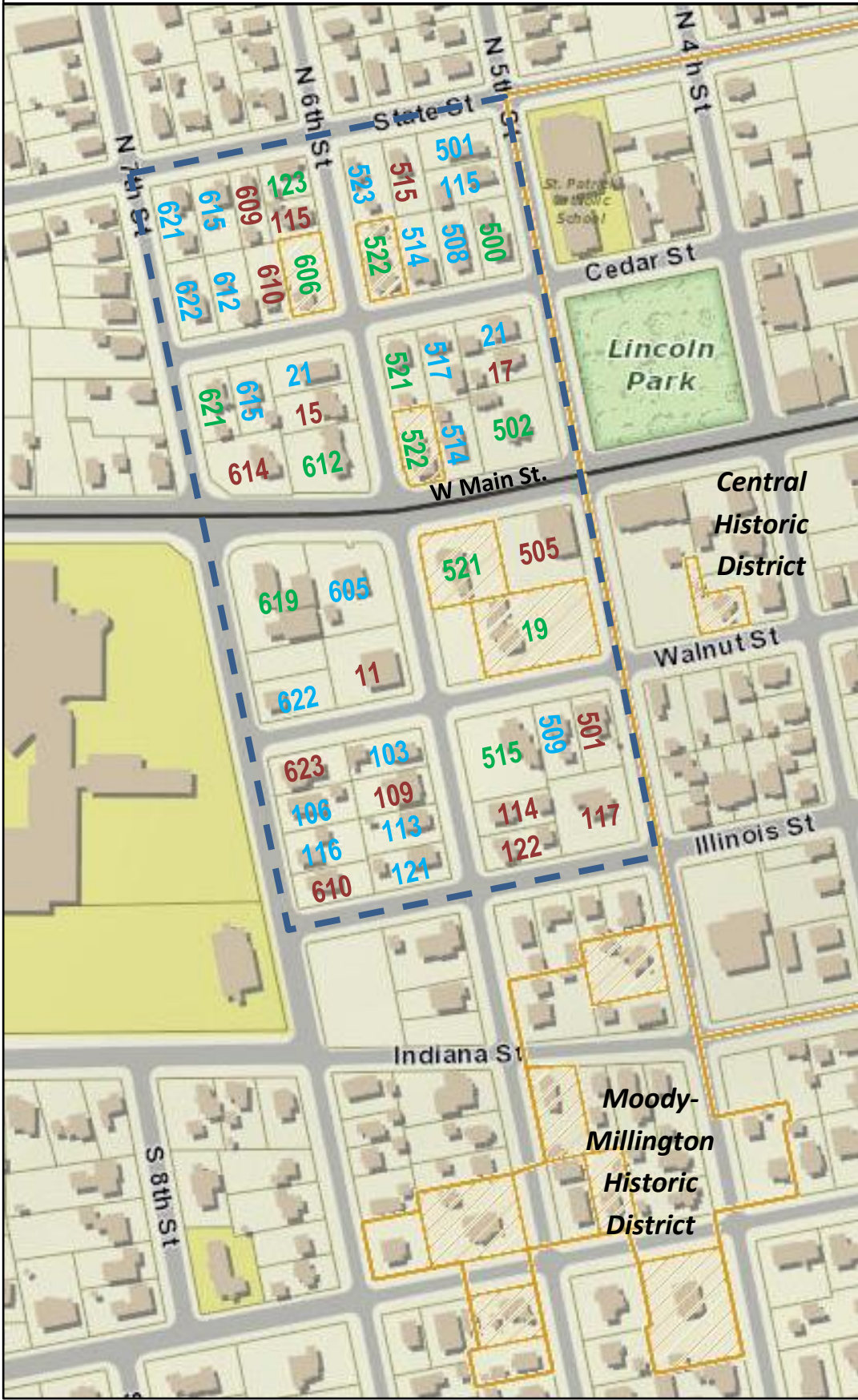

FILED - AUGUST 15, 1842
RECORD BOOK 2 PAGE 498

JOHN B. PRESTON
SURVEYOR

Millington Historic District Architectural Survey Information



-  District Boundary
 -  Existing Historic District
 -  Historic Landmark
- Architectural Significance Rating:
-  Significant (13)
 -  Contributing (22)
 -  Non-Contributing (16)

Survey information taken from the Near West Side Survey conducted in 2003 and updated as necessary in 2016